



Key Features

- Maintenance Free
- Robust Construction
- 100Hz Data Rate
- Speed of Sound and Sonic Temp Outputs
- Custom Calibrated
- Analogue Outputs
- Optional Analogue and PRT Inputs

Specification

Wind Speed

Range	0 - 45 m/s
Resolution	0.01 m/s
Accuracy	<1% RMS

Direction

Range	0 - 360°
Resolution	1°
Accuracy*	<±1° RMS

Speed of Sound

Range	300-370 m/s
Resolution	0.01 m/s
Accuracy	< ±0.5% @ 20°C

Measurement

Ultrasonic sampling rate	100 Hz
Parameters	UVW, Speed of Sound

Digital Output

Communication	RS422 full duplex, 8 data bits, 1 stop bit, no parity
Baud rates	2400 - 115200
Output rate	Selectable 0.4 to 100Hz

Analogue Inputs (via optional SIU)

Quantity	6 differential inputs
Sampling rate	100Hz
Range and resolution	±5V, 14 bits
Accuracy	<0.1% of FSR

The R3-100 combines the latest electronic components with Gill Instrument Ltd's considerable experience in producing solid state ultrasonic anemometers for micrometeorological research. It take as its pedigree the world leading Solent Research R2 which have been proven time and time again to be constant and reliable instruments for the study of wind and its turbulence parameters.

The R3-100 has a faster response time, up to 100Hz, and operating system, RCOM, designed to be robust and simpler to use. The resolution of the analogue outputs has been greatly improved to 14bits whilst the high accuracy and measurement resolution of the solent research has been maintained. Optional extras such as the inclinometer are available as well as a sensor input unit to allow upto 6 analogue sensors plus a PRT100 input.

*Supplied Accessories - RCOM operating system with a graphical interface (data presentation and storage; flux calculations); power supply (PCIA); Transit Case.
Optional Accessories - Analogue and PRT Inputs via Signal Interface Unit (SIU); Inclinometer.

Analogue Outputs (via supplied PCIA)

Quantity	7 (U, V, W, SoS, PRT plus 2 analogue inputs)
Sampling	±10, ±20, ±30, ±60 m/s
Update rate	0.4 to 100Hz
Range and resolution	±2.5V, 14 bits
Accuracy	<0.25% of FSR

PRT Input (requires optional IU, PRT 100 not included)

Input resolution	0.01°C
Input accuracy	<0.01°C (0 to 50°C) < 0.15°C (-40°C to +60°C)

Inclinometer (optional)

Range and resolution	±20°C, 0.01°
Null repeatability	± 0.15°
Accuracy	±0.3° (from -10° to 10° of inclination)

Power Requirement

Anemometer	9-30V dc <4w (eg. <150mA @ 24V DC or 300mA @ 12V dc)
------------	--

Environmental

Protection Class	IP65
Operating Temp	-40°C to +60°C
Precipitation	Operation to 300 mm per hour
EMC	BS EN 50081-1: 1992 (Emissions) BS EN 50082-1: 1992 (Immunity)
Suitable for exposure to a marine environment	

*Accuracy spec applies for wind speed <32 m/s and for wind incidence <±150° in the horizontal plane and up to ±50° from the horizontal.

Typical Applications

- Wind Turbulence Measurement
- Component Wind Velocity UVW
- Wind Profiling



Dimensions

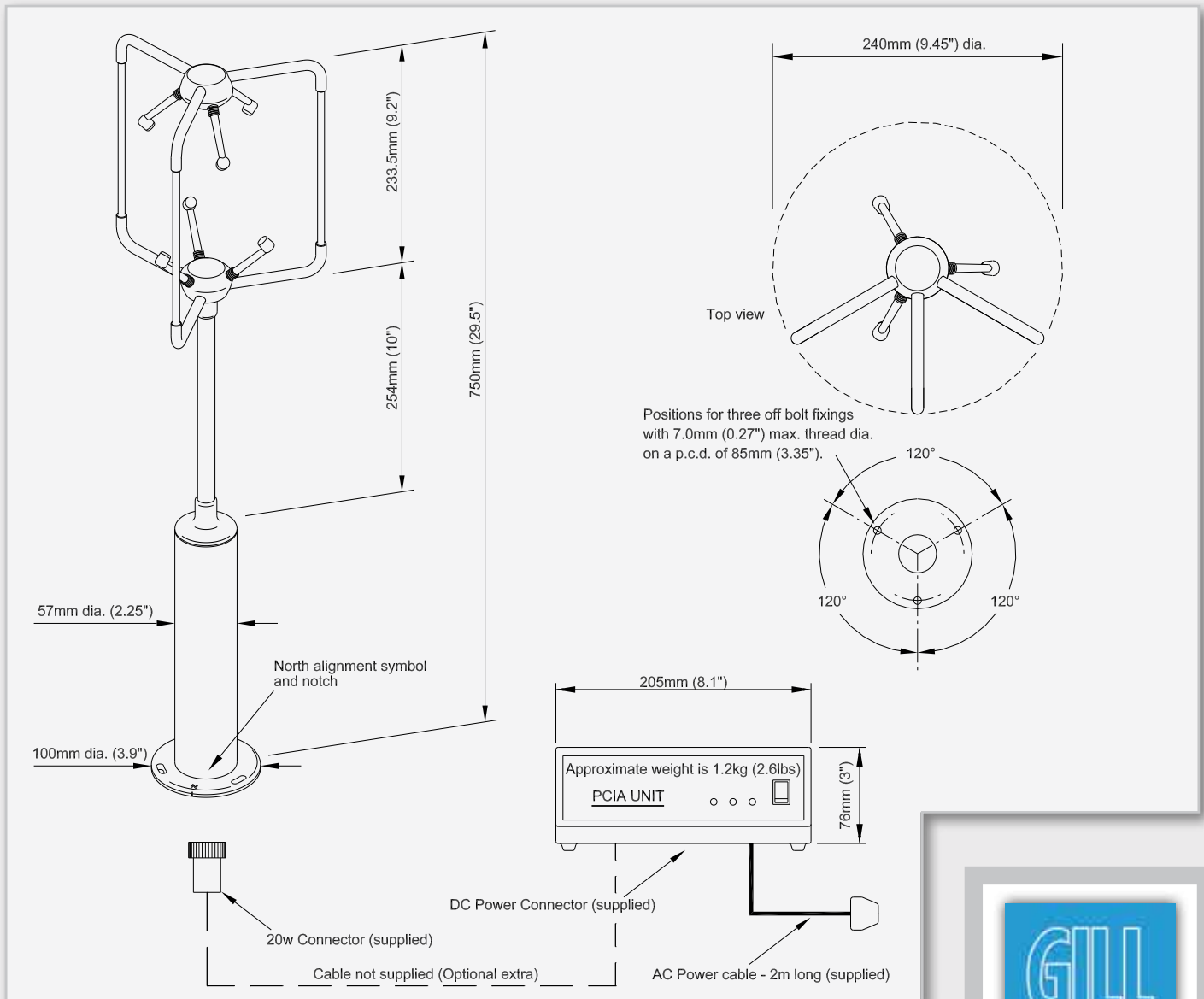

The R3-100 is part of the Solent range of ultrasonic anemometers.
 The range is in continuous development and therefore specifications may be subject to change without prior notice.

