

September 2008  
Version 1.34

Scintec Surface Layer Scintillometer

# User Manual

SLS20 / SLS40  
SLS20-A / SLS40-A

(including OEBMS1)



**Scintec AG**  
Wilhelm-Maybach-Str. 14  
72108 Rottenburg  
Germany

Tel [+49]-7472-98643-0  
Fax [+49]-7472-9808714  
E-Mail [info@scintec.com](mailto:info@scintec.com)  
[www.scintec.com](http://www.scintec.com)







## Contents

IMPORTANT NOTE ON LASER SAFETY CONSIDERATIONS .....	1
QUICK REFERENCE GUIDE.....	2
1 INTRODUCTION.....	3
2 HARDWARE PREPARATION.....	4
2.1 SELECTION OF PATH.....	4
2.2 INSTALLING THE INSTRUMENTS.....	5
2.3 ALIGNMENT.....	7
2.4 REDUCTION IN LASER POWER .....	11
3 OPTICAL ENERGY BALANCE MEASUREMENT SYSTEM OEBMS1.....	13
3.1 DESCRIPTION OF PERIPHERAL SENSORS .....	13
3.1.1 Pyrradiometer .....	13
3.1.2 Pyranometer .....	14
3.1.3 Aspirated Radiation Shield and Temperature Sensor PT 1000 .....	15
3.1.4 Self-Calibrating Soil Heat Flux Sensor HFP01SC.....	16
3.1.5 Barometric Pressure Sensor.....	17
3.2 SETTING UP THE OEBMS1-TOWER.....	18
3.3 MOUNTING THE PERIPHERAL SENSORS .....	20
3.4 CARRYING OUT THE WIRING .....	25
3.4.1 Wiring of Pyrradiometer.....	26
3.4.2 Wiring of Pyranometer.....	29
3.5 SETTING UP THE SOIL HEAT FLUX SENSORS .....	29
3.6 OVERALL WIRING SCHEME.....	30
4 SOFTWARE.....	31
4.1 INSTALLATION.....	31
4.2 MAIN MENU .....	31
4.3 ALIGNMENT PULL-DOWN MENU.....	33
4.3.1 Level Screen.....	33
4.3.2 Automatic.....	33
4.4 SETTINGS PULL-DOWN MENU .....	34
4.4.1 Path / Air.....	34
4.4.2 Periods.....	36
4.4.3 Output.....	36
4.4.4 Background.....	38
4.4.5 Time.....	39
4.4.6 Hardware .....	39
4.4.7 Advanced.....	42
4.4.8 Automatic Alignment.....	44
4.5 VIEW DATA PULL-DOWN MENU .....	44
4.5.1 Graphics .....	44
4.5.2 Editor .....	45
4.6 PERFORMING A MEASUREMENT .....	45
4.6.1 Starting a measurement.....	45

4.6.2	Real time data display and graphics .....	45
4.6.3	Terminating a measurement .....	53
4.7	DESCRIPTION OF SLSRUN VERSION 2 OUTPUT FILE FORMATS .....	53
4.7.1	Main data output file .....	53
4.7.2	Diagnosis data output file .....	55
4.7.3	Extra channel data output file .....	56
4.7.4	Covariance data output file .....	57
4.7.5	Raw data output file .....	58
4.7.6	OEBMS1 data output file .....	58
4.8	UTILITIES PULL-DOWN MENU .....	60
4.8.1	Recalculate Turbulence Data Utility .....	60
4.8.2	Increase Averaging Time utility .....	61
4.8.3	Suppress Errors utility .....	62
4.8.4	$C_n^2$ Height Profiles utility .....	63
4.8.5	Convert Data Format utility .....	64
4.8.6	The program SLSFIL .....	64
APPENDIX A	THEORY .....	66
APPENDIX B	DESCRIPTION OF THE INSTRUMENTS .....	70
B.1	TRANSMITTER AND RECEIVER UNITS .....	70
B.1.1	General .....	70
B.1.2	Orientation of tubes .....	71
B.1.3	Pinhole adjustment .....	71
B.1.4	Amplifier dip switch setting .....	72
B.1.5	Source lifetime and operation temperature range .....	73
B.2	JUNCTION/CONTROL BOX .....	73
B.2.1	Power supply .....	73
B.2.2	Source control .....	76
B.2.3	Overvoltage protection .....	76
B.2.4	Connectors .....	77
B.3	CARD SPC20 .....	78
B.3.1	General .....	78
B.3.2	Regulators and dip switches .....	79
B.3.3	Connectors .....	81
B.4	COMMUNICATION BETWEEN SPC20 CARD AND ISA BUS .....	82
B.4.1	General .....	82
B.4.2	Base address .....	82
B.4.3	Communication test .....	82
B.4.4	Computer speed .....	83
B.5	PROCESSING UNIT SPU20 .....	84
B.5.1	General .....	84
B.5.2	Connection and power supply .....	84
APPENDIX C	SPECIFICATIONS .....	87
APPENDIX D	AVOIDING MEASUREMENT ERRORS .....	89
D.1	STABILITY OF THE MOUNTING PLATFORMS .....	89
D.2	LOW SIGNAL-TO-NOISE RATIO .....	89
D.3	INNER SCALE MEASUREMENT RANGE .....	90
D.4	CROSSTALK .....	90
D.5	MISALIGNMENT .....	91

D.6	DIFFERENT INTENSITIES IN THE TWO CHANNELS.....	91
APPENDIX E	ERROR AND WARNING CODES .....	92
APPENDIX F	CALIBRATION OF EXTRA CHANNEL DATA.....	95
APPENDIX G	INTERFACING/CALIBRATION OF OEBMS1 SENSORS .....	96
APPENDIX H	INTERFACING/CALIBRATION OF SLSDMI SENSORS.....	98
APPENDIX I	CE DECLARATION OF CONFORMITY.....	100

## **Important Note on Laser Safety Considerations**

The SLS20 / SLS20-A / SLS40 / SLS40-A is a class 3a laser product.

During the operation of this instrument, harmful visible laser radiation is emitted.

Never look into the laser beam or at any specular reflections of the laser beam as long as you are not at a safe distance\*.

Never use optical instruments, in particular binoculars or telescopes, to look at the laser beam, even if you are at a safe distance for the naked eye.

Attach appropriate warning signs and prevent unauthorized personnel from approaching the source.

\*Always be at least 50 m away from the source when looking at it from the frontal side (see section 2.3).

## Quick Reference Guide

The following steps are required to perform a measurement with the SLS20(-A) / SLS40(-A):

1. Install the software SLSRUN Version 2 (Section 3.1)
2. Configure the software's communication parameters (Sections 3.2 and 3.4.6)
3. Check the correct communication between the SPC20 plug-in card / SPU20 Processing Unit (respectively) and the PC, change the communication parameters if necessary (Appendix B.4)
4. For crosswind measurements, calibrate the conversion time (Section 3.4.6)
5. Select all parameters in the Settings menu (Section 3.4)
6. Setup and align the SLS20(-A) / SLS40(-A) transmitter and receiver (Chapter 2)
7. Determine the background signal and crosstalk coefficients (Section 2.3 g)
8. Start the measurement (Section 3.6)

View and postprocess the measured data if desired (Sections 3.5, 3.7, and 3.8)

## 1 Introduction

The SLS20(-A) / SLS40(-A) is a sophisticated scintillometer system for accurate measurements of atmospheric turbulence. The instrument combines outstanding performance and ease-of-operation. It has the following features:

- reliable laser diode source
- modulated radiation for elimination of background
- extremely sensitive, shot noise limited detector unit
- interference filter for use in direct sunlight
- operation over a single path with displaced beam technique
- unaffected by turbulence inhomogeneities along the path
- correction for transmitter vibrations (SLS40, SLS40-A)
- automatic beam steering (SLS20-A, SLS40-A)
- heated windows to prevent dew and ice deposits
- path length and height user defined
- rapid installation and alignment with positioning device
- comfortable operation on PC with expansion card or separate processing unit with RS232 connection
- user-friendly software for real time data evaluation
- background calibration and crosstalk correction
- comprehensive error identification and correction
- calculation of structure function constant  $C_n^2$  and inner scale  $\ell_0$  of refractive index fluctuations
- calculation of structure function constant  $C_T^2$  of temperature and dissipation rate  $\varepsilon$  of kinetic energy
- calculation of Monin-Obukhov length and turbulent fluxes of heat and momentum
- screen graphics output in real time and from file
- possibility of data export via communication links
- 11 additional input channels for free disposal by the user
- rugged weather-resistant design

The SLS20 / SLS20-A / SLS40 / SLS40-A is patented under U.S. PAT. 5,303,024 and DE 39 02 015 C2, others pending.

## 2 Hardware Preparation

### 2.1 Selection of Path

The propagation path length is defined as the distance between the centre of the transmitter and the centre of the receiver (see Fig. 1):

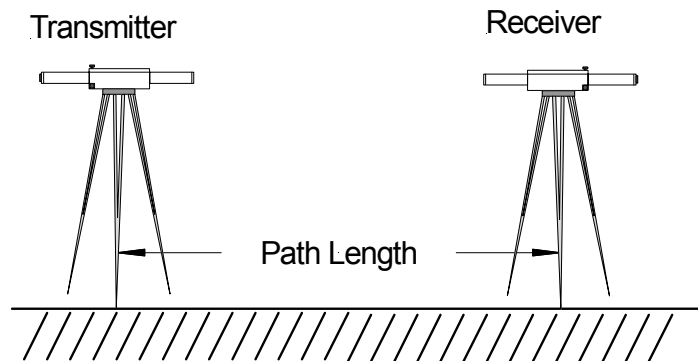

**Figure 1:** Illustration of the path length definition

Operation of the SLS20(-A) / SLS40(-A) is possible over paths in the range 50 to 300 m. The recommended path length is 100 to 200 m.

The propagation path should be horizontal, the ground should be as even as possible. A well defined measurement height is required for application of the Monin-Obukhov similarity theory. Note that the primarily measured quantities  $C_n^2$ , i.e. the structure function constant of refractive index fluctuations, and  $\ell_0$ , i.e. the inner scale of refractive index fluctuations, strongly depend on height and a slant path would lead to an undesired averaging.

The path height is defined as the height of the straight line connecting the transmitter and the receiver above ground. If the surface is not totally flat, use the average height with an increased weight at the path's centre. The path weighting functions (describing the contribution of different positions along the path) are given in Appendix A., Figs. A.1 and A.2. A typical measurement height for a path length of 100 to 200 m is 1.50 to 2.00 m.

When selecting the path length and height, technical and site requirements should be considered:

- a) The calculation of the turbulent fluxes and the Monin-Obukhov length is based on Monin-Obukhov similarity. Monin-Obukhov similarity requires the measurement height to be significantly larger than the height of the roughness elements.

- b) Monin-Obukhov similarity also requires homogeneity of the site over several tens of times the measurement height upwinds. Therefore, poor site homogeneity suggests a lower measurement height.
- c) For long propagation paths, saturation may occur under strong turbulence conditions (see Appendix A and Appendix E). Saturation is avoided by using a sufficiently short propagation path or a large measurement height. In other words, larger path lengths suggest larger measurement heights.
- d) The path length changes the measurement range and sensitivity. For typical turbulence conditions, a 100 - 200 m long path provides an optimum sensitivity to the inner scale and all derived quantities.
- e) With short paths the intensity fluctuations are small, with long paths the average received intensity is small. Both affect the signal-to-noise ratio. A 100 - 200 m path length usually provides an optimum.

After you have chosen the path position and length you must:

- a) Enter the path length and height in the Settings / Path/Air submenu of the SLSRUN software (see Section 3.4.1).
- b) Adapt the amplifier dip switch setting in the receiver unit (see Appendix B.1.4).

## 2.2 Installing the instruments

The transmitter and receiver units must be mounted on stable platforms. The required angular pointing stability is in the order of 0.1 mrad / 1 mrad (SLS20(-A) / SLS40(-A)) at the transmitter and 1 mrad at the receiver.

We recommend the use of heavy tripods used for geodetic purposes. The 5/8 inch threads at the bottoms of the instruments allow an easy connection to such devices. Strong winds (around 10 m/s or more) may require additional measures to ensure pointing stability and to avoid measurement errors caused by vibration of the transmitter (see Appendix D.1), especially with the SLS20 / SLS20-A.

Before doing the alignment it is important to check:

1. The source and receiver tubes must be correctly placed in the positioning devices. Verify that the rotational positions around their main axes are correct (see Appendix B.1.2). Since the two beams are identified by polarization, incorrect orientation will produce a considerable crosstalk of the signals. For the same reason make sure later that the whole instruments are correctly mounted in the horizontal.

2. After transportation or mechanical shock, the spatial filter pinhole in the transmitter unit might need repositioning (see Appendix B.1.3).

Then connect the SLS20(-A) / SLS40(-A) receiver unit with the JCB. Connect the SLS20(-A) / SLS40(-A) transmitter unit with the JCB (required for auto background mode) or provide a local power supply for the transmitter unit.

### **If you use the card(s) SPC20 in the ISA bus slot of your PC:**

Plug the card SPC20(s) into the PC. If the PC has not been tested to communicate correctly with the card(s), it is recommended to perform a communication test in a laboratory before you measure. Detailed instructions are given in Appendix B.4. Connect the Junction/Control Box with the SPC20 card(s) using the supplied cable.

SLS20: If your PC supplies the required currents at +12V and -12V (0.1A at +12V and 0.05A at -12V for SLS20, see Appendix C) you do not need a separate power supply, even though it is recommended to use one especially during longer experiments. This protects the PC from voltage spikes which may be induced in the long cables, caused by electric discharges in the atmosphere. To use the PC's internal power supply, set the switch at the Junction/Control Box (JCB) to "int" (intern, see section B.2.1). Alternatively, connect an external 12V power supply to the JCB (see Appendix B.2.1) and set the switch to "ext" (extern). When the switch is in the middle position, transmitter and receiver are disconnected.

SLS20-A, SLS40, SLS40-A: With one of these systems you must connect an external 12 to 18V power supply to the Junction/Control Box (JCB), the exact voltage value depending on the cable lengths to the transmitter and receiver. For details see Appendix B.2.1. Set the switch at the JCB to "ext" (extern). The instrument will not work properly with the internal 12V of the PC (switch in "int" position), except if you have a transmitter cable length of 150 m or less and a receiver cable length of 50 m or less, and the PC provides the current needed (see Appendix C). When the switch is in the middle position, transmitter and receiver are disconnected.

### **If you use the processing unit SPU20:**

Connect the SPU20 with the serial port of the PC (COM1 or COM2) and select COM1 or COM2 in the Settings / Hardware submenu of the SLSRUN software (see Section 3.4.6). Connect the Junction/Control Box (JCB) with the SPU20 processing unit (connector named "to SPU20 / to PC"). Provide the SPU20 processing unit with +12 V operation power (see Appendix B.5.1.). The SPU20 then needs 60 seconds to boot up.

SLS20: Set the switch of the JCB to the "int" position.

SLS20-A, SLS40, SLS40-A: With one of these systems you must connect an external 12 to 18V power supply to the Junction/Control Box (JCB), the exact voltage value depending on the cable length to the transmitter or receiver. For

details see Appendix B.2.1. Set the switch at the JCB to "ext" (extern). The instrument will not work properly with the internal 12V of the PC (switch in "int" position), except if you have a transmitter cable length of 150 m or less and a receiver cable length of 50 m or less. When the switch is in the middle position, transmitter and receiver are disconnected.

### **Overvoltage protection:**

To protect the instruments and the PC against damages caused by overvoltage (atmospheric electric discharges), connect the ground connector of the JCB with a suitable ground.

Note that the JCB and the SPU20 are not weather proof and should be kept indoors close to the PC.

### **Weather protection:**

It is important to avoid cases temperatures of more than 50°C during operation. In hot and sunny climates, the instruments should therefore be operated at a naturally ventilated place or a sun protection shield should be used.

The transmitter and receiver of the SLS20(-A) / SLS40(-A) withstand normal rain and snow and usually can be operated outdoors without further protection.

The instruments are not totally sealed. During heavy rain, small amounts of water may penetrate into the interior of the instruments. This will not affect the operation and will dry due to natural air exchange. However, after heavy rain, do not move or shake the instruments.

Measures to protect the instruments from direct precipitation are recommended for permanent installations or under severe weather conditions.

## **2.3 Alignment**

It is recommended that two persons perform the alignment, one person at the transmitter and one person at the receiver. Walky-Talkies are helpful.

The alignment is easiest in the following order:

- a) Roughly align the transmitter unit: Look through the alignment hole in the transmitter (see figure in Appendix B.1.1) and adjust the platform (tripod) until you see the receiver in the middle of the hole. With the SLS20-A or SLS40-A, run the SLSRUN program, go into the Alignment pull-down menu, select the Automatic screen and invoke the Center Beam command. This moves the beam to the central position. Attention: The beam must be centered always

before a manual alignment or realignment. The person at the receiver side should then be able to visually find the beam by looking at the transmitter and walking around. Within the beam, he sees a very bright red spot at the transmitter.

**Danger: The source unit emits laser radiation which is harmful for the human eye in the vicinity of the instruments. Always make sure that you are at least 50 m away from the source when looking into the beam! Never look into the beam as long as you are not behind the receiver's position!**

- b) Roughly align the receiver unit: Look through the alignment hole in the receiver and adjust the platform (tripod) until the transmitter is in the middle of the hole.

**Attention:** During the alignment of the transmitter and receiver, make sure that you do not tilt the platform out of the horizontal. A strictly horizontal transmitter and receiver position is required to maintain the defined polarization direction to each other. Otherwise you will later notice a considerable crosstalk.

- c) Make the fine adjustment of the transmitter with the three positioning screws of the positioning device. It is recommended that you first align in the vertical direction. To do this, loosen the upper screw. By turning the lower screws in the same sense, you move the beam up and down.

After you have found the correct vertical position, fasten the upper screw and perform the alignment in the horizontal. To do this, turn the lower screws in an opposite sense which moves the beam to the left or to the right.

The goal of the transmitter alignment is to have the receiver as close as possible to the beam's centre. When judging the beam's position one must take into account that the beam has an elliptic cross section. The optimum position of the receiver is indicated by an "O" in the following sketch (Fig. 2):

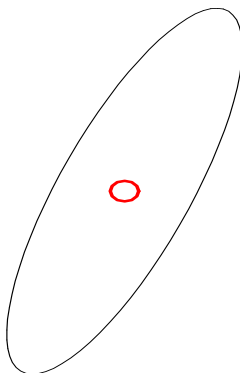

**Figure 2:** Illustration of the elliptic beam cross section

Do the fine adjustment very carefully, especially with the SLS20 and SLS40. Usually a few iterations are required. The SLS20-A and SLS40-A will do the

final fine alignment automatically, if you have configured the software accordingly in the Automatic Alignment submenu of the Settings pull-down menu (see section 3.4.8). When you finish the alignment, make sure that the screws are properly fastened.

- d) To perform the receiver fine alignment, run the SLSRUN program and select the Level screen in the Alignment menu (see section 3.3.1). Perform a scan-like movement of the receiver tube using the positioning screws as described above until vertical bars appear on the screen. The bars indicate the signal strengths at the two detectors. The left two bars ("instantaneous") represent the instantaneous signal and usually fluctuate strongly (due to the scintillation to be measured). The right two bars ("average") represent the signal averaged over the last few seconds (running mean). The averaging takes out most of the fluctuations and facilitates the alignment if the alignment is performed slowly enough that the bars have time to follow.
- e) When you scan the receiver in the vertical and horizontal you will notice that there is a range where the signals of both channels are at maximum. **The final position should be in the centre of this range (in the horizontal and in the vertical direction).**

Note that it is not required that the signal levels of the two channels are similar and that both channels have a slightly different field of view with a large overlapping region.

In order to facilitate the alignment there are triangles on the screen indicating the maximum and minimum levels measured so far. When the alignment is finished, the left (averaged) vertical bars should be close to the upper triangles (maximum values). The triangles can be reset by pressing the <F1> key.

- f) Adapt the signal levels with the channel level regulators at the Junction/Control Box for channels 1 and 2 (with the SLS40(-A): channels 1A and 2A) until they are in the optimum range. For path lengths of 100 to 200 m, this range is marked on the screen by two horizontal lines (700 to 1400 digits). Turn the regulators until the averaged signals have levels in between. It is not necessary that both signals have the same level.

For paths shorter than 100 m or longer than 200 m, set the levels as close as possible to the optimum range. For short paths (< 100 m), you can run the instrument with signal levels above the optimum range since the intensity fluctuations are expected to be small then. For long paths (> 200 m), you can run the instrument with signal levels below the optimum range since large intensity fluctuations will improve the signal-to-noise ratio.

If the average signals are too weak:

1. Check the alignment of the transmitter.
2. Check the alignment of the receiver.

3. Check the pinhole adjustment at the transmitter (see Appendix B.1.3).
4. Check the dip switch setting in the receiver unit (see Appendix B 1.4).
5. Check if there is dirt, dew or ice deposit on the windows.

If none of the above suggestions help, increase the receiver output by selecting the next higher amplifier dip switch setting in the receiver (see Appendix B.1.4).

If the signals are too strong, select the next lower amplifier dip switch setting in the receiver (see Appendix B.1.4).

**Note that relative changes of the intensity will be evaluated. Therefore the adjustment of the signal levels only optimizes the operation and has only minor effects on the accuracy of the results.**

With the **SLS40** or **SLS40-A**, the following procedure is required in addition:

While being in the Alignment / Level screen, press the <F4> key. Instead of the first pair of detectors (1A and 2A), this will display the signals of the second pair of detectors (1B and 2B) on the screen. Turn the level regulators for channels 1B and 2B such that the levels of these channels are in the range of the levels of channels 1A and 1B. Again press the <F4> key to reselect display of channels 1A and 2A.

- g) Measure the background signal and crosstalk coefficients by invoking the Measure Background option in the Settings / Background submenu (see section 3.4.4). You will be asked in a dialogue to first allow measurement of the undisturbed signal, then to cover the whole beam to allow measurement of the background (manual action is not necessary if the transmitter is connected to the Junction/Control Box) and then to cover the beams of channel 1 and channel 2 separately to allow measurement of the crosstalk.

The coverage of the beams must be performed directly at the beam exit of the transmitter. Use a small piece of paper which is transparent enough so you can see the position of the covered beam. Be careful to totally obscure the beam to be covered and not to touch the other beam.

If the software recognizes that the beam to be covered was not perfectly covered or the other beam was touched, you will be informed and asked to repeat the procedure.

After that procedure, the measured coefficients will be displayed. Check if they are ok:

The mean values <X> and <Y> should be in the range 5 to 25 digits. If one or both of them are outside this range, repeat the Measure Background procedure. If one or both mean values are still outside, adjust the offset of the

SPC20 card or the SPU20 processing unit (see Appendix B.3.2).

The standard deviations  $\text{sigX}$  and  $\text{sigY}$  should be below 10 digits. If one or both of them are larger, repeat the Measure Background procedure. If one or both standard deviations are still larger and you are using the SPC20 card(s) in the PC, perform the communication test (see Appendix B.4).

The crosstalk coefficient should be below or at about 5%. If one or both of them are considerably larger, repeat the Measure Background procedure. If one or both crosstalk coefficients are still larger, bring the transmitter and receiver in a correct horizontal position and repeat the Measure Background procedure. If still one or both crosstalk coefficients are larger than 5% and you are using the SPC20 card(s) in the PC, perform the communication test (see Appendix B.4).

The background values and crosstalk coefficients determined during this procedure are used to correct the data during the measurement. There are three selectable options in the Settings / Background submenu.

- "Use File Data": the measurements will be corrected using the values determined during this procedure.
- "Ignore": no background and no crosstalk information will be considered. In this case, step 2.3 g is not required.
- "Automatic": the background measurement will be automatically repeated in certain intervals. However the crosstalk coefficients will be used as determined during this procedure.

**Note: Alignment using a retroreflector (corner reflector)**

A retroreflector (corner reflector) of at least 0.2 m diameter can support a single person to do the alignment. Put the retroreflector on top of the receiver. First align the transmitter for maximum reflection which can be seen at the transmitter side very close to the transmitter. After that, verify the correct position at the receiver side and re-adjust the transmitter if necessary. Finally align the receiver as described before.

## **2.4 Reduction in Laser Power**

A reduction in laser power of the SLS20/40 or SLS20-A/40-A Transmitter Unit might be required for very short path lengths (under about 70 m). The reduction prevents a potential saturation of the receiver, which may result in an apparent loss of received signal. To reduce the power, follow the steps given below:

1. Remove the back-cover of the SLS Transmitter Unit. For this, unscrew the three Phillip head screws at the transmitter end hosting a connector with 4

pins (SLS20, SLS40) or 7 pins (SLS20-A, SLS40-A). Pull out carefully the metal cylinder (see Fig. 1). The latter contains a module controlling the laser operation. **Note: Do not extract the metal tube completely.**



**Figure 1:** Removing the back-cover of the SLS Transmitter Unit

2. There are three different potentiometers on the module. The furthest behind potentiometer allows a reduction in laser power (arrow in Fig. 2.).

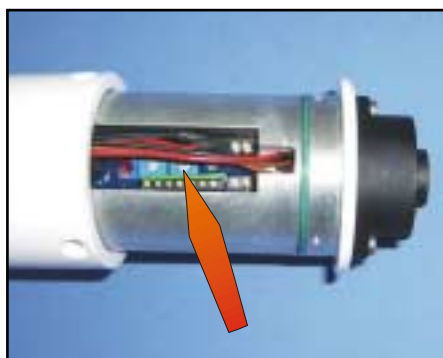

**Figure 2:** Identifying the appropriate potentiometer

3. To reduce the power of the laser, turn the potentiometer screw counter-clockwise to around 20-40% of its maximum position (default setting).

**Note:** When changing to large path lengths, do not forget to increase the laser power to its nominal value.

### 3 Optical Energy Balance Measurement System OEBMS1

The Optical Energy Balance Measurement System OEBMS1 allows to measure surface energy budgets. Unlike conventional stations, the OEBMS1 employs optical scintillation to obtain the turbulent heat flux. This results in a high accuracy even with short averaging periods. While conventional stations need averaging times of 30 to 60 minutes, the OEBMS1 resolves all components in 5 minutes steps - virtually without statistical scatter and representatively characterizing large experimental areas. For comparison, about 100 eddy correlation sensors mounted on masts along the optical propagation path would be required to achieve a similar performance.

The OEBMS1 consists of the following:

- Scintillometer SLS20 system (other models also possible), including
  - Receiver
  - Transmitter
  - Junction Control Box JCB
  - Set of data cables
  - Set of power supply cables
  - Tripods
- OEBMS1 Signal Processing Unit SPU
- Schenk Pyrradiometer, model 8111
- Schenk Pyranometer, model 8101
- Two Gill Aspirated Radiation Shields with thermometers PT1000
- Three Hukesflux Soil Heat Flux Sensors, model HFP01SC
- Young Barometric Pressure Sensor 61202V
- Metal tower with three guy lines, three metal pegs and two spikes
- Controller plate (mounted on tower) with three controller (CONSH1 #1, CONSH1 #2 and CONSH1 #3) , one CONSH1 Multiplexer and one PT1000 Sensor Interface
- Three controller (CONSH1 #4, CONSH1 #5 and CONSH1 #6) connecting the three Soil Heat Flux Sensors to the controller plate
- Set of data cables
- Set of power supply cables

#### 3.1 Description of Peripheral Sensors

##### 3.1.1 Pyrradiometer

The Pyrradiometer is used to measure precisely the net radiative flux in the wavelength range 0.3 to  $> 30 \mu\text{m}$ . The net radiative flux is the difference between the radiative power received from (or emitted to) the upper hemisphere and the radiative power received from (or emitted to) the lower hemisphere, where both refer to the same horizontal plane.

The operation principle of the instrument is based on the measurement of the difference between the case temperature and the temperature of two horizontal sensor planes, one looking upwards and one looking downwards, respectively. The case temperature is sensed separately.

The sensor planes are two blackened metal surfaces at the lower side and the upper side of the instrument, each of them thermally connected to the instrument's body via a thermocouple. The voltages generated at these two thermocouples are separately available at the output of the instrument. The upper surface senses the shortwave solar radiation and the long wave thermal radiation from the atmosphere. The lower surface sense the solar radiation reflected at the ground and the long wave thermal emission of the ground. The heavy aluminium body of the Pyrradiometer results in a high thermal inertia. A built-in Pt100 resistance thermometer provides the body temperature for the calculations of the upward and downward radiative fluxes.

Each of the two receiving surfaces is topped by a highly sensitive polyethylene dome. Two drying cartridges protect the interior from water vapour condensation. Two circular bubble levels facilitate the horizontal adjustment.



**Figure 3:** Pyrradiometer

**Attention:**

**Do not touch the polyethylene domes topping the receiving surfaces of the Pyrradiometer. The domes are highly sensitive and might be destroyed by direct contact.**

### 3.1.2 Pyranometer

The Pyranometer enables one to measure the global radiation. The global radiation is defined as the sum of the direct solar radiation and the diffuse sky radiation in the spectral range 0.3 to 3  $\mu\text{m}$ .

The Pyranometer contains 12 receiving copper surfaces, which are alternately painted in black and white. The regular pattern of black and white sensor surfaces is topped by a dome of polished Schott glass. The design of the instrument excludes an influence of the ambient temperature on the measurement. Therefore, only a single dome is needed.

When radiation is received, the alternately colored sensor surfaces heat up. Radiative and convective cooling limit the increase of temperature until an equilibrium temperature is reached. Since the black surfaces absorb more energy than the white surfaces, the equilibrium temperature of the black surfaces is higher than that of the white surfaces. The temperature difference is proportional to the incoming radiative flux.

The temperature difference is measured by a series of thermocouples. They generate an output voltage being proportional to the incoming radiative flux. The thermocouples are connected to the bottom side of the copper plates.

A drying cartridge protects the interior from water vapour condensation. Three levelling screws and a circular bubble level facilitate the horizontal adjustment.



**Figure 4:** Pyranometer

### **3.1.3 Aspirated Radiation Shield and Temperature Sensor PT 1000**

The Gill Aspirated Radiation Shield provides maximum sensor protection from incoming short wave solar radiation and outgoing long wave radiation while maintaining excellent sensor contact with ambient air.

The shield employs concentric downward facing intake tubes and a small canopy shade to isolate the sensor from direct and indirect radiation. A continuous duty blower draws ambient air across the sensor as well as between the inner and outer shield tubes minimizing heat transfer to the sensor. Unlike other designs, the small

overall shield size reduces the surface area exposed to incoming radiation during day thus reducing the amount of heat which needs to be removed from the intake tubes. The effect of outgoing radiation at night is similarly reduced.

The shield material is a specially formulated plastic featuring high reflectivity, low thermal conductivity, and a maximum weather ability. Brushless electronic communication is achieved using dependable solid state circuitry. Universal brackets allow convenient tower mounting with the mounting arm extending to provide additional clearance from the tower.

The Platinum Temperature Probe is a 1000  $\Omega$  RTD sensing element encased in a stainless steel sheath and available in various output options. The sensor is fitted with a plastic junction box for convenient cable connection and proper positioning in the shield.

The 4 – 20 mA current output is useful in high noise, industrial settings or for long cable lengths. The 0 – 1 VDC option provides a calibrated voltage output signal. Both sensor interfaces operate over a wide temperature range and include protection from high voltage transients.



**Figure 5:** Gill Aspirated Radiation Shield

#### **3.1.4 Self-Calibrating Soil Heat Flux Sensor HFP01SC**

The HFP01SC self-calibrating heat flux sensor is a thermal sensor intended for high accuracy measurement of soil heat flux. The online calibration automatically corrects for various common errors, in particular those due to the non-perfect matching of the thermal conductivity of sensor and soil and due to variations of the thermal conductivity of the soil caused by varying moisture content.

The heat flux sensor HFP01SC is a combination of a heat flux sensor and a film heater. The primary purpose is to estimate the heat flux through the surrounding soil. The output is a voltage signal that is proportional to the heat flux through the sensor. The film heater that is mounted on top can be activated to perform a calibration, resulting in a new calibration factor that compensates for the error made under the circumstances of that moment. Implicitly, also cable connection, data acquisition and data processing are tested, and additional information is obtained on the thermal conductivity of the soil. Also errors due to temperature dependence and instability of the sensor are eliminated.



**Figure 6:** Soil Heat Flux Sensor HFP01SC

Please note that the measurement of the soil thermal conductivity is not available anymore, due to product improvements which are related to the use of the new Soil Heat Flux Sensor. The scintillometer operation software indicates this by displaying the dummy value 9.999.

### 3.1.5 Barometric Pressure Sensor

The barometric pressure sensor is an electronic barometer featuring high accuracy, low power, wide operating temperature range, and calibrated outputs in several forms.

Low power consumption and wide temperature range make the 61202V ideal for remote applications using battery or solar power. Accuracy better than  $\pm 1$  hPa is maintained over the entire pressure and temperature ranges. The barometer includes full duplex RS232 and half-duplex RS485 serial connections and is configured for voltage output.

The standard pressure scale for analog output spans 600 to 1100 hPa. A narrower range may be selected via software menu.



**Figure 7:** Barometric Pressure Sensor

### 3.2 Setting up the OEBMS1-Tower

In order to set up the OEBMS1-tower, proceed as follows:

1. Screw the two spikes firmly into the two screw threads in the base plate (see Fig. 8). The two spikes avoid a slipping of the tower bottom.



**Figure 8:** Attaching spikes to the base plate

2. Put up the tower in vertical position on solid ground.
3. The tower comes with three different types of clamps (see Fig. 9), which are already attached to the vertical bars of the tower.

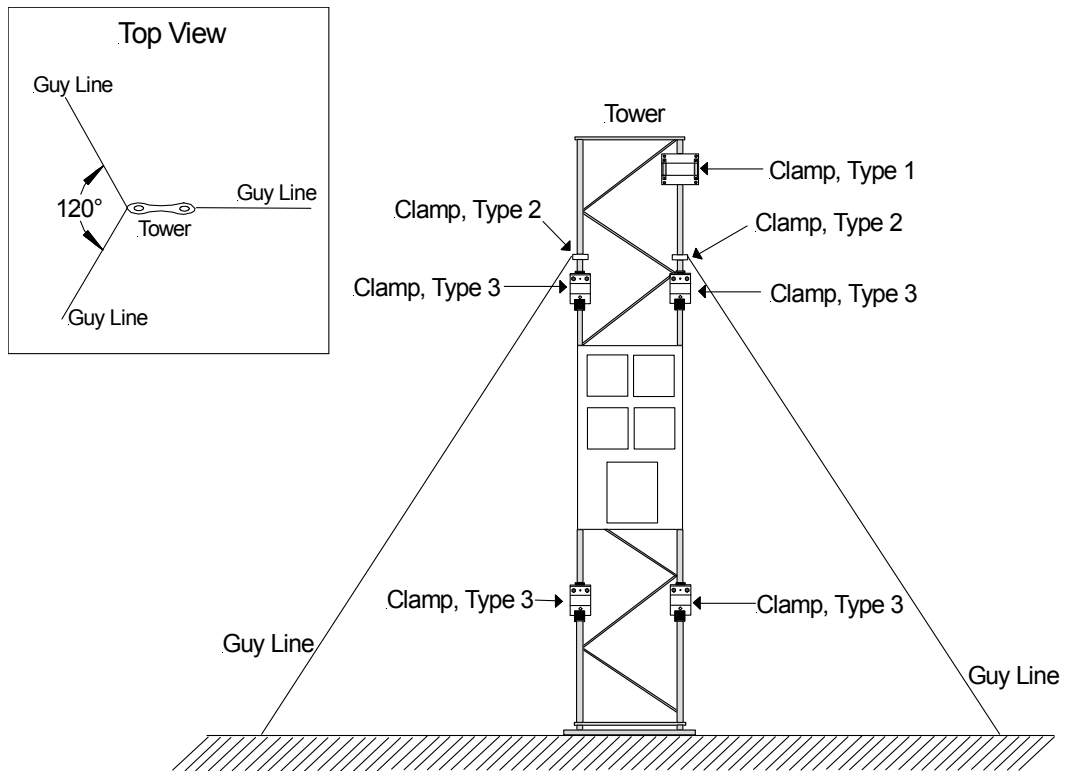

**Figure 9:** OEBMS1-Tower and Clamps

4. Attach the three guy lines to the two clamps of type 2 (see Fig. 10).



**Figure 10:** Type 2 clamps for attaching the guy lines

5. Stick the three metal pegs firmly into the ground such that the azimuth angle between the guy lines is approximately 120° (see Fig. 9, top view), and attach the open end of the guy lines to the metal pegs (see Fig. 11) by using the hook. Please note that the hook is adjustable. This allows to tighten the guy lines.

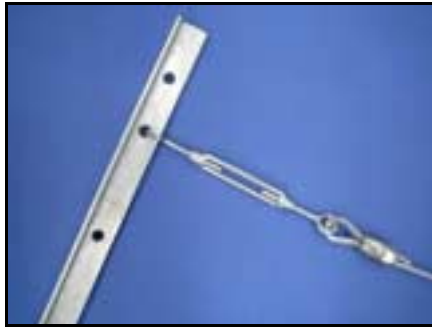

Figure 11: Metal peg and guy line with hook

### 3.3 Mounting the Peripheral Sensors

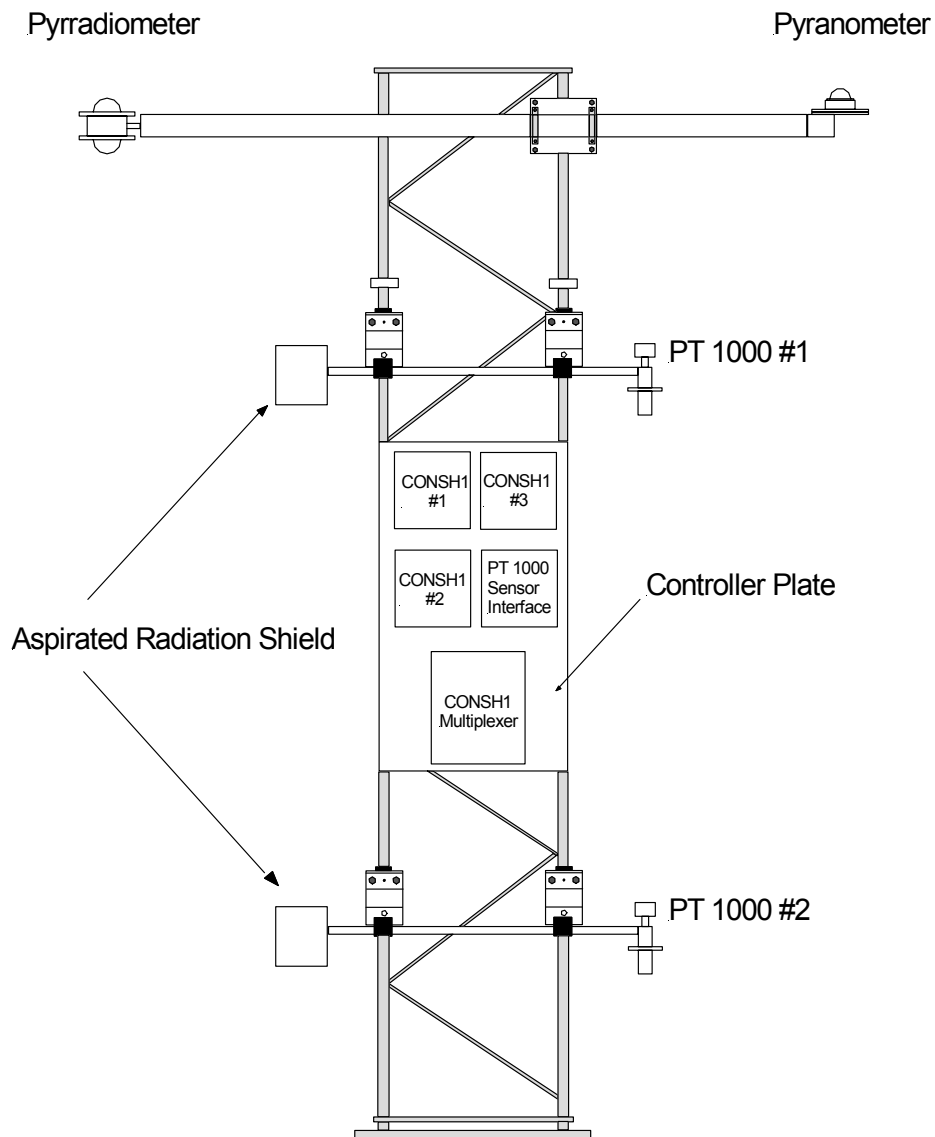

Figure 12: OEBMS1-tower and peripheral sensors

1. Attach the long, gray mounting arm (Fig. 13) to the tower by using the single clamp of type 1 (Fig. 9 and Fig. 14). The holes serve as penetrations for the Pyrradiometer and Pyranometer cables. Stickers at the two ends of the arm indicate the positions of the Pyrradiometer and Pyranometer.

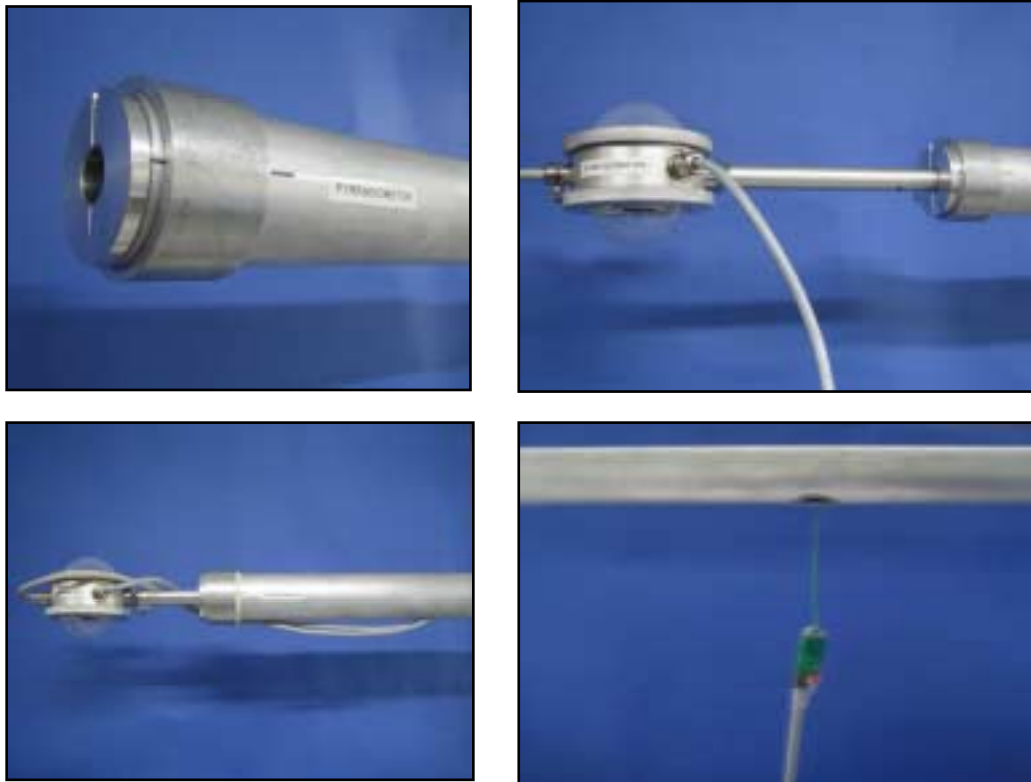

**Figure 13:** Mounting arm for Pyrradiometer and Pyranometer



**Figure 14:** Type 1 clamp

2. Plug the small mounting arm of the Pyrradiometer into the end of the main mounting arm (Fig. 15, upper panels). Ensure correct orientation of the green and yellow dots, which can be seen under the polyethylene domes (Fig. 19). The Pyrradiometer should be positioned approximately 10 cm from the end of the mounting arm (Fig. 15, lower left panel).



**Figure 15:** Attaching the Pyrradiometer to the mounting arm

In order to guide the two cables through the cable holes, a green taut wire is guided through the cable penetration. Fix the two Pyrradiometer cables to the taut wire by using tape (Fig. 15, lower right panel) and pull the green wire, together with the two Pyrradiometer cables, through the mounting arm.

3. Plug the Pyranometer into the other end of the mounting arm (Fig. 16) and tight the screw.

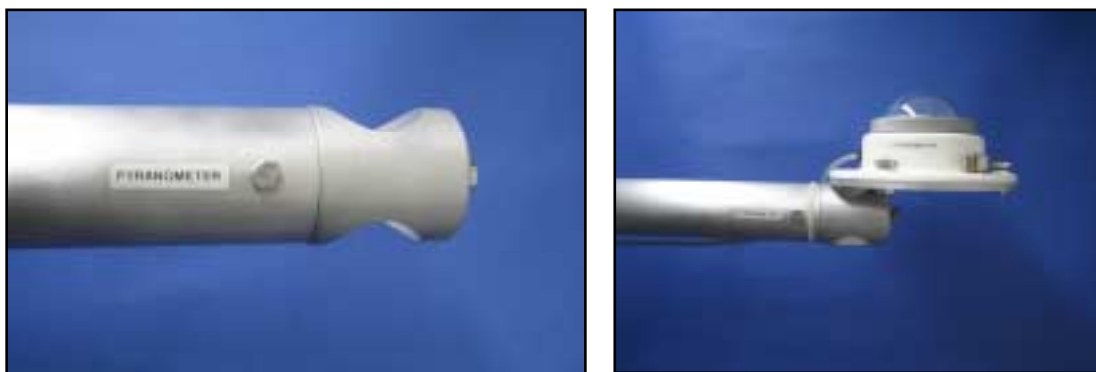

**Figure 16:** Attaching the Pyranometer to the mounting arm

In order to guide the Pyranometer cable through the cable holes, proceed in the same manner as for the Pyrriadiometer cables and use the second green taut wire for guiding the Pyranometer cable through the mounting arm.

4. Connect the two Pyrriadiometer cables and the one Pyranometer cable with cable tie and fix the bunch to two crossbars of the tower (Fig. 17).



**Figure 17:** Connecting the cable bunch to the crossbars

5. Roll up the Pyrriadiometer cable which will not be used (see also Fig. 19) and fix it with cable tie to the crossbar behind the controller plate (Fig. 18)



**Figure 18:** Not connected Pyrriadiometer cable

6. In order to mount the upper Aspirated Radiation Shield to the tower, connect the two black brackets, which are attached to the white tube of the Aspirated Radiation Shield (Fig. 5), to the upper type 3 clamps ( Fig. 19).

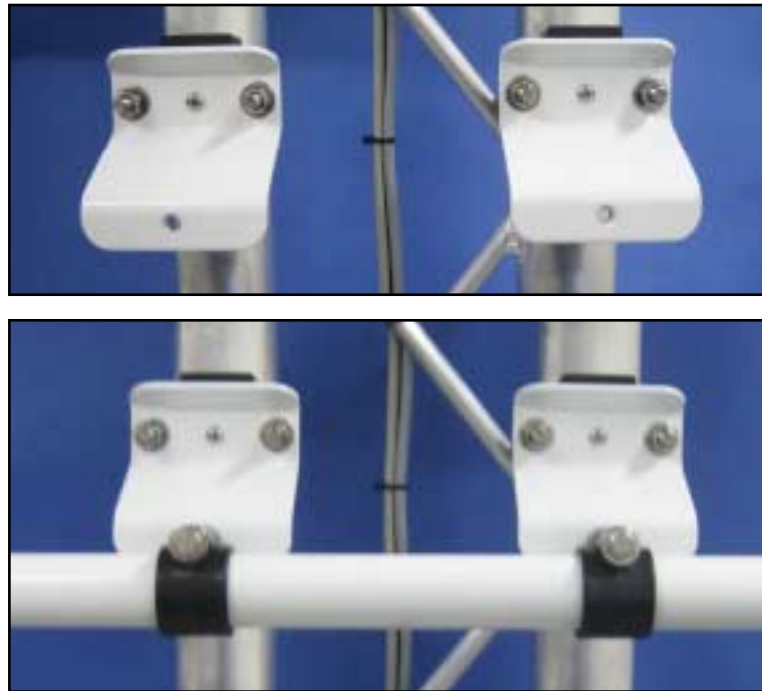

**Figure 19:** Type 3 clamps for mounting the Aspirated Radiation Shield

7. To attach the temperature sensor PT 1000 #1 to the tower, stick the temperature probe PT 1000 #1 into the open end of the Aspirated Radiation Shield (Fig. 20) and tight the white screw.



**Figure 20:** Mounting the upper temperature sensor PT 1000 #1

8. To attach the second Aspirated Radiation Shield to the tower, connect the two black brackets to the lower type 3 clamps (Fig. 19). Proceed in the same manner as in step 7 to mount the temperature sensor onto the Aspirated Radiation Shield. A completely assembled Aspirated Radiation Shield together with its related temperature probe PT 1000 is shown in Figure 21.

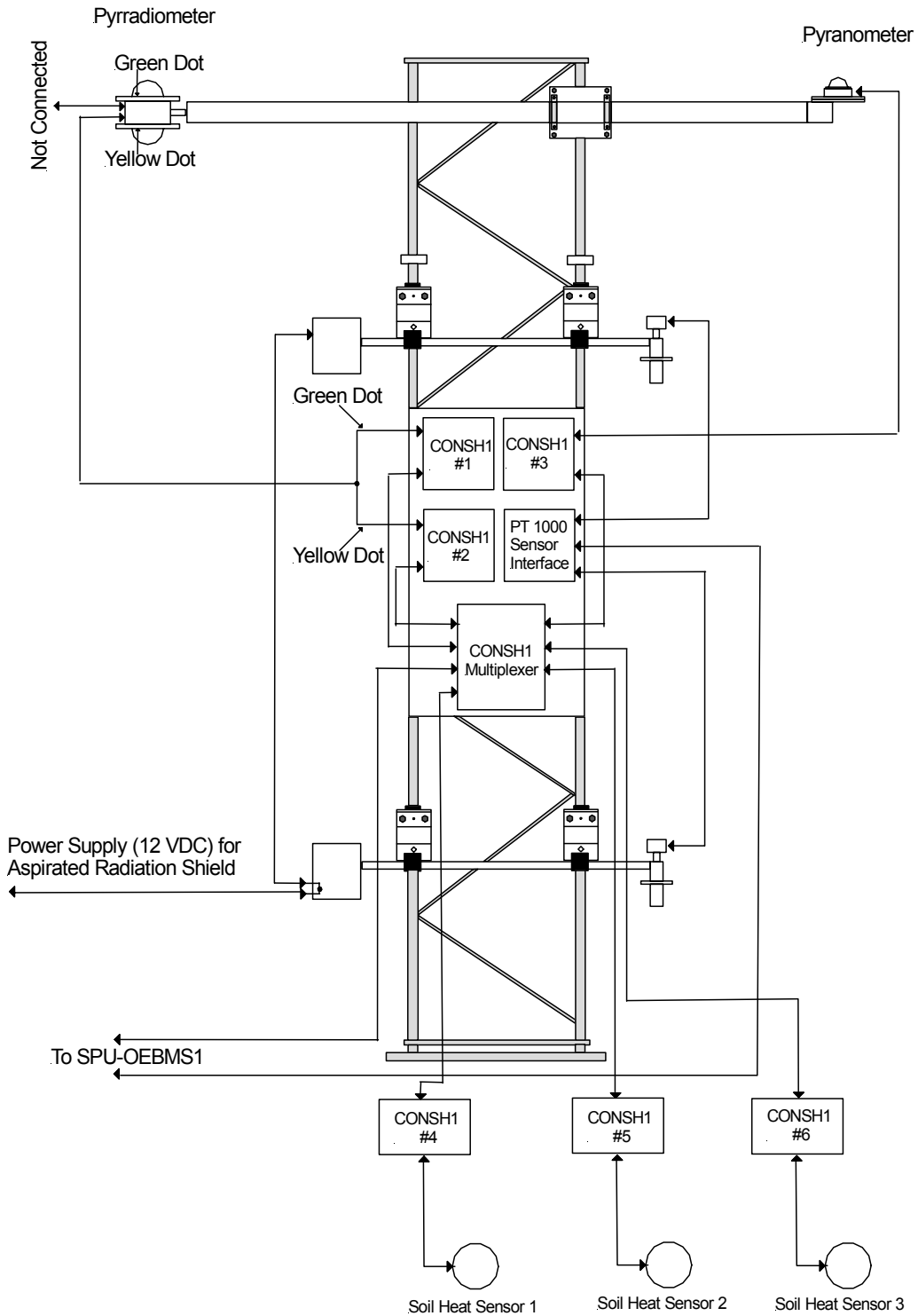

**Figure 21:** Aspirated Radiation Shield and temperature probe attached to the tower

### 3.4 Carrying out the Wiring

After having set up the OEBMS1-tower and having attached the peripheral sensors by mounting arms, the Pyradiometer and Pyranometer have to be connected to the controller boxes CONSH1 #1, CONSH1 #2 and CONSH1 #3. All three controller boxes are mounted onto the controller plate (Fig. 22).

The wiring of all peripheral components as well as the three Soil Heat Flux Sensors is illustrated in Figure 22.



**Figure 22:** Wiring diagram of OEBMS1-tower and Soil Heat Flux Sensors

### 3.4.1 Wiring of Pyrradiometer

The Pyrradiometer cable is split into two different cable branches (Fig. 23), which have to be connected to terminal screw joints inside the controller boxes CONSH1 #1 and CONSH1 #2.



**Figure 23:** Pyrradiometer cable

To connect the Pyrradiometer cable to the controller boxes CONSH1 #1 and CONSH1 #2, open the two boxes. Diagrams showing the wiring of the printed circuit boards are shown on the inside of the top covers. Guide the cable with the green and white wire through the open connector of controller box CONSH1 #1 (Fig. 24). The corresponding cable end is labelled with #1.



**Figure 24:** Connecting the Pyrradiometer cable to CONSH1 #1

Screw the green and the white wire into the first terminal screw joint as shown in Figure 22.

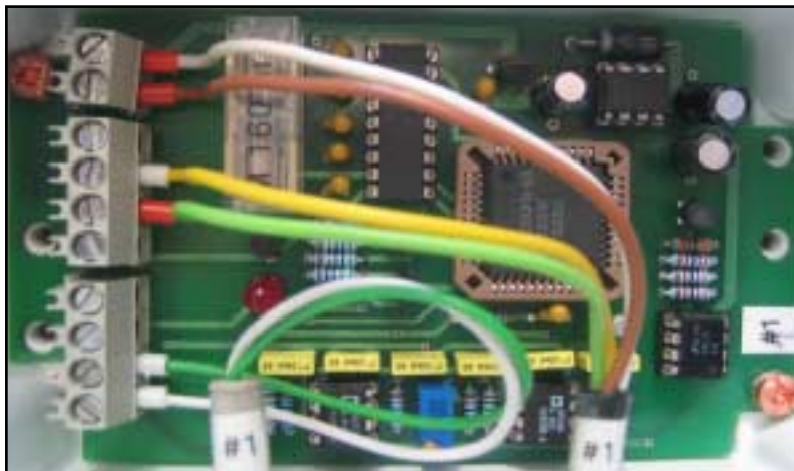

**Figure 25:** Connecting the Pyrradiometer cable to CONSH1 #1

Guide the second Pyrradiometer cable branch (labelled #2) through the open connector of controller box CONSH1 #2. Connect the yellow and brown wires to the first terminal screw joint as shown in Figure 23.



**Figure 23:** Connecting the Pyrradiometer cable to CONSH1 #2

### 3.4.2 Wiring of Pyranometer

In order to connect the Pyranometer cable to the controller box CONSH1 #3, open the box and guide the brown and white wires through the open connector of controller box CONSH1 #3 (see Fig. 24). The cable end is labelled with #3.

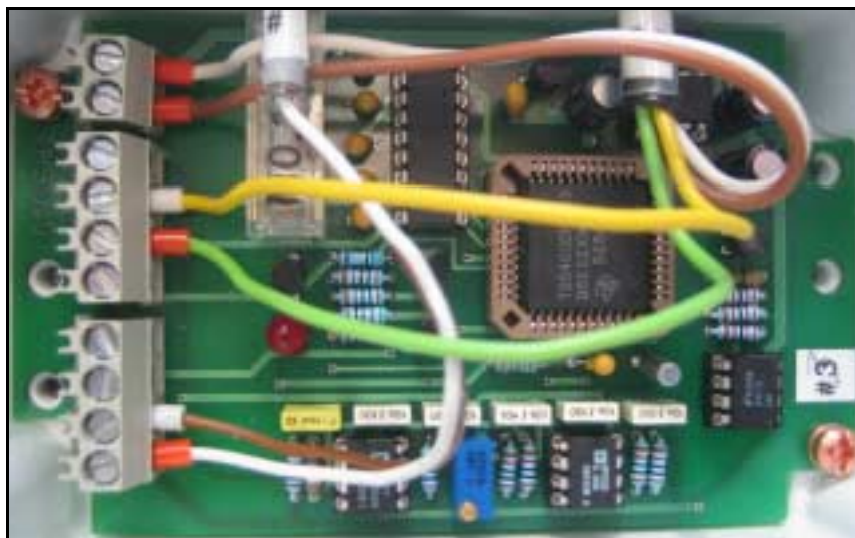

**Figure 24:** Connecting the Pyranometer cable to CONSH1 #3

### 3.5 Setting up the soil heat flux sensors

All three soil heat flux sensors are connected to the CONSH1 Multiplexer via the controller boxes CONSH1 #4, CONSH1 #5 and CONSH1 #6. In order to achieve best performance of the sensors, it is recommended to remove the upper layer (approximately 5 cm) of the soil in form of one slice. Put one of the three sensors into the hole with the red side up and cover the sensor with the soil unit initially removed. The medium surrounding the sensor should be as homogeneous as possible. Proceed in the same manner to install the remaining two soil heat flux sensors.

### 3.6 Overall Wiring Scheme

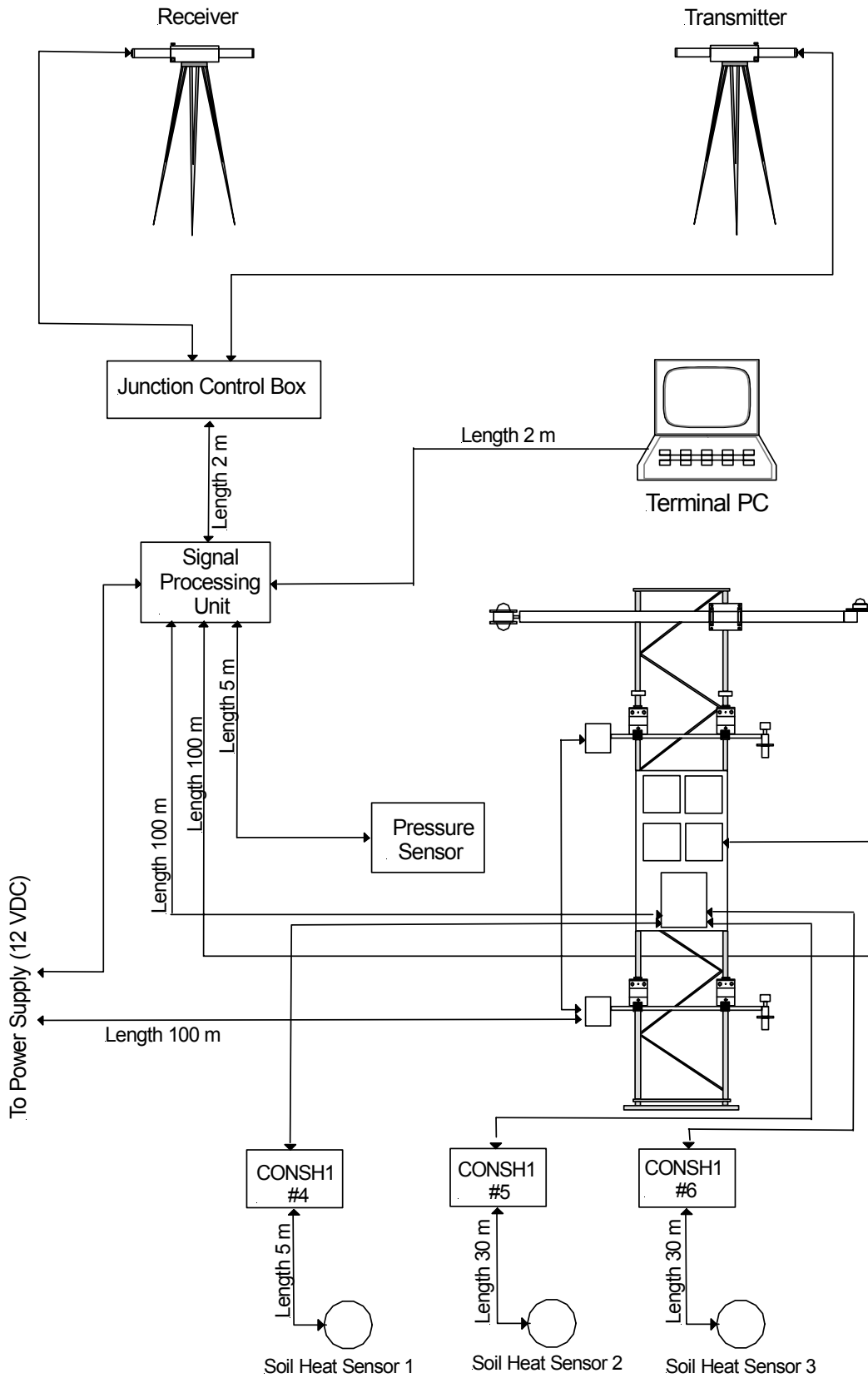

Figure 25: Wiring of OEBMS1-Tower, soil heat flux sensors and SLS

## 4 Software

### 4.1 Installation

The SLSRUN Version 2 program runs on an IBM compatible PC with a 486 or higher processor and a minimum frequency of 66 MHz. If the crosswind shall not be measured or the processing unit SPU20 is used, a 386 processor with 20 MHz (preferably with coprocessor) is sufficient.

The SLS series scintillometers with Signal Processing Unit (RS232 version) can be operated under DOS and Windows(TM) 95/98/NT/ME/2000/XP Operating Systems.

For SLS series scintillometers without Signal Processing Unit (ISA bus version) it is recommended to call SLSRUN from the DOS level. If the crosswind shall be measured, do not call SLSRUN from Windows and terminate all memory resident programs before, except the mouse driver, if needed.

The software comes on a CD containing the file INSTALL.BAT and an additional folder containing the SLS software.

For the OEBMS1, the file "slsconsh.dat" is needed in addition. This file contains the sensor calibrations and is delivered separately.

To install the software, click on INSTALL.BAT and follow the instructions.

### 4.2 Main menu

After you called SLSRUN, the main menu appears. On the header line, you find the 5 menu command fields

- Main
- Alignment
- Settings
- View Data
- Utilities

Each of these menu command fields headlines a pull down menu grouping several submenus or subcommands. The pull down menus become visible by

- highlighting the Main menu command field with the <Alt> key, moving with the <Cursor left> and <Cursor right> keys to the respective menu command field and pressing the <Cursor up>, <Cursor down> or <Return> key

or

---

- with the <Alt> key being pressed, pressing the first letter of the menu command field

or

- mouse click on the menu command field.

You then select the submenus or subcommands by

- moving with the <Cursor down> and <Cursor up> keys to the respective submenu or subcommand field and pressing the <Return> key

or

- mouse click on the submenu or subcommand field.

You return to the main menu by repetitively pressing the <Alt> key or the <Esc> key.

Within the screens of the activated submenus, you move forward from window to window or from option to option with the <Tab> key, and backward with the <Shift> + <Tab> keys. You can alternatively select the window by mouse click.

There are text windows and option windows. In a text window you edit the content by simply typing and deleting the text or number. In an option window you select or unselect the option by pressing the <Space> key. Alternatively you can do this by mouse click.

After you have changed parameters and/or options, you accept them by leaving the submenu via the OK field. With the Cancel field you leave without changes.

In the main menu, the screen shows several boxes containing parameters, names, and options defined by the Setting submenus (the titles of the boxes corresponding to the submenus). This allows you to easily check the major settings before you start a measurement.

These submenus can also directly be activated by double mouse click on the respective box, allowing a quicker change of the settings.

To start a measurement, go into the Main pull-down menu and select the "Start Measurement" subcommand (see Section 3.6).

To leave SLSRUN, go into the Main pull-down menu of the main menu screen and select the "Exit SLSRUN" subcommand.

## 4.3 Alignment pull-down menu

### 4.3.1 Level Screen

You enter the Level screen by selecting the Level command.

In the upper left side of the Level screen, a display indicates the intensity in the two (SLS40(-A): main) channels (SLS20(-A): channels 1 and 2, SLS40(-A): channels 1A and 2A) as vertical bars. The numbers correspond to the output of the AD converter. 12 bit resolution means a range from 0 to 4095. The instantaneous intensities are displayed by the left two bars and a sliding temporal average of the intensities is displayed by the right two bars. The averaging eliminates a large part of the fluctuations and allows to judge the mean intensity levels more easily.

At the top of each bar, there are two triangles marking the maximum and minimum values observed so far. The triangle position can be reset by pressing <F1>.

During the measurement, the Average intensity bars should stay between the horizontal min and max line or close to this range most of the time. For path lengths below 100 m they may stay somewhat higher, for path lengths above 200 m they may stay somewhat lower.

In the box below, the bar graph display is magnified for the AD converter output range 0 to 50. This facilitates finding the signal at low levels and also permits a visual check of the offset (laser switched off or covered) which should be in the range 5 to 25.

In the upper right graph, the recent temporal behaviour of the instantaneous intensities of both channels is displayed as curves.

In the box below, the instantaneous intensities, the average, and the minimum and maximum values since the last reset are shown numerically for both channels.

SLS40(-A): When you press the <F4> key, the signals of the detector pair 1B and 2B are displayed instead of pair 1A and 2A. The channels 1A and 2A are displayed again after you pressed the <F4> key a second time.

### 4.3.2 Automatic

The submenu "Automatic" is used to bring the beam of an SLS20-A or SLS40-A into a defined position.

If you invoke the "Center Beam" command, the beam will be moved into the central position. This is always required before you perform a manual transmitter alignment.

The "Perform Complete Alignment" command brings the beam into an optimum position, i.e. the position with the maximum level at the receiver. Invoke this command before you measure, unless you selected the Alignment At Beginning option in the Automatic Alignment submenu of the Settings menu. Note that it is required that the receiver is well aligned before an automatic alignment is performed. The Complete Alignment is composed of a sequence of a "Raw Alignment", a "Fine Alignment" and a "Superfine Alignment".

The "Raw Alignment" command lets the system perform the first part of the complete alignment procedure only. It will only prealign the transmitter beam. The resulting accuracy will be higher under conditions of weak turbulence.

The "Fine Alignment" command lets the system perform the central part of the complete alignment procedure only. This is sufficient under weak turbulence conditions if the receiver already sees some signal.

The "Superfine Alignment" command lets the system perform the last part of the complete alignment procedure only. The Superfine Alignment improves the beam position if it is already close to its optimum.

In the lower part of the Automatic Alignment submenu of the Alignment pull-down menu, the present beam position is indicated.

In the "beam distance" window, the distance of the beam from the central position is given in percent of the possible scan range. 0% means that the beam is in the centre while values close to 100% mean that the beam reached to outer area of the scan cone. To account for future drifts of the setup you should perform a manual re-alignment if the beam distance approaches values of 80% or more.

In the "beam angle" window, the angle of the beam displacement from the centre is given in degrees (0-360°).

## 4.4 Settings pull-down menu

All measurement parameters are defined in the Setting pull- down menu, containing the following submenus:

### 4.4.1 Path / Air

#### **Window "Path Length in m":**

Enter the optical propagation path length in m here. If this is outside the range 50 - 300 m, you must generate the calibration data file with the program SLSFIL first (see Section 3.8.6).

The correct path length setting is required for the correct realtime calculation of all

derived turbulence parameters. Note that measurement results may be recalibrated for other path lengths using the Recalculate Turbulence Data utility after a measurement (see Section 3.8.1).

#### **Window "Path Height in m":**

Here the height of the optical propagation path must be entered in m. This information is needed if the turbulent fluxes and the Monin-Obukhov length are to be calculated. The required accuracy is a few per cent.

If the ground is not perfectly even, average the height over the propagation path, taking the path weighting function of the scintillometer into account (see Appendix A, Figs. A.1 and A.2).

Note that measurement results may be recalibrated for other path heights using the Recalculate Turbulence Data utility after a measurement (see Section 3.8.1).

#### **Window "Air Temperature in °C":**

If you do not use the SLSDMI-1 option, enter the air temperature in centigrade here. An estimation within 5° or 10° is sufficient in most cases since the effect on the results is small.

Note that the measurement results may be recalibrated for other temperatures using the Recalculate Turbulence Data utility after a measurement (see Section 3.8.1).

If you have a temperature sensor connected (SLSDMI-1 option, see below), you do not have to enter a value.

#### **Window "Air pressure in hPa":**

Enter the air pressure at the measurement location in hPa (= mbar, not reduced to sea level). An estimation within 10 hPa is sufficient in most cases, since the effect on the results is small.

Note that the measurement results may be recalibrated for other pressures using the Recalculate Turbulence Data utility after a measurement (see Section 3.8.1).

If you have a pressure sensor connected (SLSDMI-1 option, see below), you do not have to fill this field.

#### **Window "Connected Sensors":**

If you use the SLSDMI-1 or SLSDMI-2 option, you must select the connected sensors here (SLSDMI-1: temperature and pressure; SLSDMI-2: temperature,

temperature difference, pressure).

Then the respective value is measured directly. In the "Air Temperature" and "Air Pressure" windows the word "auto" appears.

#### 4.4.2 Periods

##### **Window "Main Data Period in min":**

The value in this window defines the averaging time for the main output data and the extra channel output data in minutes. Recommended values are 1-5 min. The main data period should ideally be a multiple of the diagnosis data period (see below).

Note that the averaging time of taken data can easily be increased after the measurement by using the Increase Averaging Time utility (see Section 3.8.2). So a selected averaging time of 1 min is the optimum in most cases.

##### **Window "Diagnosis Data Period in s":**

During the measurement, the data are evaluated in packages being shorter than the main data period. These shorter periods are named "diagnosis data periods". Each main data period consists of a number of diagnosis data periods. Only error-free diagnosis data periods form the basis for the calculation of the output in intervals of the main data period.

The length of the diagnosis data period is specified in this window. It must be long enough to achieve a statistically significant sample. However, it should not be too long as this leads to data loss in the case of an error. The recommended value is 6 s.

#### 4.4.3 Output

##### **Window "Output File":**

This window defines the names and the path (directory) of the output files. Enter the file names without extension. The extensions will be set according to the definitions listed below.

Optionally, the "Auto File Name" option can be selected. In this case the PC opens new output data files every midnight, hence splitting long uninterrupted measurements into individual daily files. Then the name of the main data output file will be "YYMMDD.XXX", where YY is the year (e.g. 96 for 1996), MM is the month, DD is the day, and XXX is the extension (see below).

The SLSRUN software stores the turbulence data in a file with the extension ".res".

The "Save Main Data" option should always be selected except for test purposes. No main output data are stored then.

The "Include Crosswind" option can be selected only if the delivered software includes the Crosswind Extension SLSCW-20. If selected, the crosswind data will be evaluated and output in the same file as the turbulence data (extension ".res"). Do not select this option unless you need the crosswind data because the computational time for the crosswind algorithm is subtracted from the time available for sampling and processing the turbulence data (see information on Efficiency in the Turbulence Data output screen, Section 3.6.2).

If the "Save Diagnosis Data" option is selected, the diagnosis data will be output in a file with the extension ".dgn". It is usually recommended to select this option.

If the "Save Covariance Data" option is selected, the time lagged covariances will be output in a file with the extension ".cov". Note that this option is for scintillation research purposes only. A large amount of data will be collected in a short time, filling the hard disk rapidly. This option is available with the Crosswind Extension SLSCW-20 only.

If the "Save Raw Data" option is selected, the digital raw data will be output in a file with the extension ".raw". Note that this option is for scintillation research purposes only. A large amount of data will be collected in a very short time, filling the hard disk very rapidly. This option is available only when used with the SPC20 card(s) in the PC.

The SPC20 card has an input for 11 additional channels for free disposal by the user. If the "Save Extra Channel Data" option is selected, the data taken at the extra channel inputs will be output in a file with the extension ".xtr".

The number of extra channels read and stored can be defined in the line below this option. The sampling rate is in the order of 1 Hz. The data are averaged over the main data periods.

### **Window "Additional Output Ports":**

The turbulence, wind, diagnosis, and extra channel data can be sent also to the serial or parallel ports of the PC. Select the desired output ports in this window.

The parallel ports are LPT1 and LPT2. They allow direct output to a printer.

The serial ports are COM1 and COM2. The port configuration must follow in a string:

COMn:speed,parity,data,stop

---

with	n:	1 or 2 specifying the communication port
	speed:	baud rate of device (75, 110, 150, 300, 600, 1200, 1800, 2400, or 9600)
	parity:	N (none), E (even), O (odd), S (space), M (mark), PE (error checking)
	data:	5, 6, 7, or 8 = number of data bits per byte
	stop:	1, 1.5, or 2 = number of stop bits per byte

Information on the serial port configuration is available in a Help screen.

#### 4.4.4 Background

##### **Window "Background Mode":**

The Background Mode defines how the signal background and the channel crosstalk is handled during the measurement. The options have the following meaning:

"Use File Data": The background data and crosstalk coefficients determined during the Measure Background procedure (see below) are used to correct the measurements.

**Attention: The "Measure Background" procedure must be executed before the measurement.**

##### **"Ignore Background": No background and crosstalk correction is applied**

"Automatic": The background is automatically determined during the measurement in a regular calibration cycle. This option requires that the transmitter is connected to the Junction/Control Box. The first diagnosis data period of each main data period is then used for the measurement of the average and the standard deviation of the background signal. During these periods the source is automatically switched off. The crosstalk information cannot be determined automatically, the values determined during the Measure Background procedure (see below) are used here. This means, the "Measure Background" procedure must be executed before the measurement.

**Note:** With the SLS20(-A), the best choice is the "Use File Data" option because the first diagnosis data period after the background measurement (laser has been switched on) might be affected by small laser power instabilities.

With the SLS40(-A), the "automatic" mode may have little advantage in some cases because laser power instabilities are corrected for.

A disadvantage of the "automatic" mode is that the sampling period is shortened by the background period (one diagnosis data period).

**Window "Measure Background":**

This procedure must always be executed before measuring in the "automatic" or the "use file data" background mode if:

1. the instruments were newly installed

or

2. a re-aligned affecting the horizontal levelling of the instruments was performed

or

3. the channel level regulators in the Junction/Control Box have been adjusted.

Details are described in Section 2.3 g.

**Window "Background Data":**

The background data stored and used for correction are displayed here. The meaning is

- <X>: Average in channel 1 (digits)
- <X>: Average in channel 2 (digits)
- sigX: Standard deviation in channel 1 (digits)
- sigY: Standard deviation in channel 2 (digits)
- Xy/Y: crosstalk of channel 1 (%)
- Yx/X: crosstalk of channel 2 (%)

**4.4.5 Time**

The Time submenu can be used to set the internal time and date of the PC. Both appears with the data on the output files.

Enter the new time and date in the respective windows. The format is HH:MM:SS (HH: hour, MM: minutes, SS: seconds) for the time and YYYY-MM-DD (YYYY: year, MM: month, DD: day) for the year.

**4.4.6 Hardware**

The screen of this submenu shows parameters referring to the hardware configuration and data communication. They must be set once after the hardware installation and usually remain unchanged further on.

**Window "Receiver/Transmitter":**

Select the connected hardware (SLS20, SLS20-A, SLS40, SLS40-A, OEBMS1) in this window.

Note that the SLS40(-A) can be run in the SLS20(-A) mode also. In this case the vibration identification and correction will not be applied.

**Window "Interface":**

Depending on your hardware, select the "SPC20 Card" (card(s) for ISA bus) or the "SPU20" Processing Unit option.

If the SPC20 card has not been tested to work properly with your PC, it is necessary that you configure the SPC20 communication settings and verify the correct communication before you measure (see Appendix B.4). A communication test is not necessary if you use the SPU20 processing unit which communicates via the serial port.

If you operate an OEBMS1, select the "SPU20" and the "OEBMS1" options. An OEBMS1 can run as a scintillometer only, if the "OEBMS1" option is not selected. All other OEBMS1 sensors (if connected or not) are ignored then.

**Window "SPU20 COM Port":**

Select here, if your SPU20 is connect to serial port 1 (COM1) or serial port 2 (COM2) of your terminal PC.

**Window "SPC20 Communication":**

For best use of the SPC20 card, the software SLSRUN Version 2.XX allows adaptation to various PC configurations by changing the

- base address for the communication with the SPC20,
- number of wait cycles between the AD conversion instructions.

These parameters are set in the Window "SPC20 Communication"

For the communication between the ISA bus and the SPC20 card, the following addresses are needed: The Base Address A specified in the first line of this window and the addresses A+1, A+2, and A+3. The second SPC20 card of the SLS40(-A) in addition uses the addresses A+8, A+9, A+10, and A+11.

On the SPC20 card, the base address A is set by a dip switch (see Appendix B.3.2). The base address setting of the SPC20 card must always be identical with the setting in the software.

In most cases the address range starting from base address DEC 256 (HEX 100) is not used by other hardware components. In this case the SLS20(-A)/ SLS40(-A) can be operated with the default setting DEC 256.

However, sometimes this address range is used by other expansion cards or internally by the PC. Then you observe interferences of various kinds (no reasonable data or erroneous measurements).

We therefore strongly recommend you to check the correct communication according to the instructions in Appendix B.4 before you measure. Otherwise unpredictable measurement errors may result.

The communication between the SPC20 card and the PC is also affected by the speed of the ISA bus. If it is too fast, the SPC20 cannot respond properly. Then the PC must be delayed by wait cycles.

SLSRUN Version 2 allows setting of 5 types of wait cycles:

- Hold wait cycles
- Multiplexer (MUX) wait cycles
- Conversion wait cycles
- Read wait cycles
- Sample wait cycles

At the beginning, try to set the sample wait cycles to 1 and all other wait cycles to 0. With slower PCs, also the sample wait cycles may be set to 0. Then test the communication according to the instructions in Appendix B.4.3. If you observe problems, increase the number for all wait cycle types (add 1 or double) until the communication works correctly. Then decrease the numbers individually for each wait cycle type to find the lowest setting with correct operation.

When the SPU20 processing unit is used, the field "SPC20 Communication" is not relevant and disabled.

### **Window "Conversion Time in $\mu$ s":**

The conversion time is needed only for crosswind measurements with the Crosswind Extension SLSCW-20. The software then derives the crosswind speed from the conversion time displayed in this window.

The conversion time is the length of one conversion cycle. It must be determined when the PC hardware has been changed, when memory resident programs have been added or removed, or when PC BIOS settings were changed.

To determine the conversion time, move to the "Calibrate" field and press <Return>. The procedure may take 1 min or longer.

Typically the conversion time value will be between 40 and 80  $\mu$ s with properly installed hardware and software.

**Command "SPC20 Histogram Test":**

After you invoked the SPC20 histogram test, the observed intensity distributions for the two channels are shown. These histograms can be reset by pressing <F1>.

You can scan the whole range 0 to 4095 with the <Cursor left> and <Cursor right> keys (Channel 1) and <Ctrl>+<Cursor left> and <Ctrl>+<Cursor right> keys (Channel 2). The highest frequency is put into the centre of the screen when you press the <F2> key.

The Histogram Test screen uses the same data-read type like the measurement modes. This permits you to test the communication between the PC and the SPC20 card, as used during the Communication Test described in Appendix B.4.3.

SLS40(-A): When you press the <F4> key, the histograms of the detector pair 1B and 2B are displayed instead of pair 1A and 2A. The channels 1A and 2A are displayed again after you pressed the <F4> key a second time.

The Histogram Test screen is not available with the SPU20 processing unit.

**Command "OEBMS1 Test":**

After you invoked the OEBMS1 test, the correct communication between the PC, the SPU-OEBMS1 processing unit and the sensor interfaces (CONSH1) is tested. This test may take about 1 min.

**4.4.7 Advanced**

The screen of this submenu defines parameters of the numerical algorithms.

The "Auto Boot" option is helpful for remote operation or automatic reboot and start after power failure (see below).

**Window "Conversion Block Size":**

When crosswind data are to be taken, the conversion block size should be set to the highest possible value, depending on the available RAM size of the PC. This usually is 32000.

When only turbulence data are taken, it is usually recommended to select a smaller number between 1000 and 10000.

The conversion block size has no effect when the SPU20 processing unit is used.

**Window "Calculation Step Turb.":**

This value is an internal parameter defining the amount of data used for the turbulence calculations. A higher value means a lower amount of data evaluated. Recommended value are in the range 2 to 10.

Increasing this value increases the sampling efficiency but lowers the statistical accuracy.

**Window "Iteration Depth Wind":**

The value in this window defines the number of iterations in the crosswind algorithm. A recommended value is 30 which may be increased to 100 if the speed of the PC allows. In general, increasing this value reduces the sampling efficiency but increases the accuracy of the wind algorithm.

This value is needed only with the Crosswind Extension SLSCW-20.

**Window "Calculation Step Wind":**

This value is an internal parameter defining the amount of data used for the crosswind calculations. A higher value means a lower amount of data evaluated. A recommended values is 30. If the sampling efficiency falls below 80%, select a value of 100 or more. Generally, increasing this value increases the sampling efficiency but lowers the statistical accuracy. This value is needed only with the Crosswind Extension SLSCW-20.

**Window "Minimum Nok for Plot in %":**

This value defines the minimum quality requirement for a data point to appear on plots (real time graphics and graphics from files). The parameter Nok (percentage of error-free diagnosis data periods within the main data period, see Sections 3.6.2 and 3.7.2) acts as a measure of the data quality. 0 % means that every data point is displayed, 100 % means that only the data points with highest quality are displayed. A recommended value is 30 %.

**Option "Auto Boot":**

If you select the "Auto Boot" option, the SLSRUN program will skip the menu screen and will immediately start to measure after it was invoked.

This allows an automatic boot (remote operation) or reboot (after temporary power failure) if the program call is included in the AUTOEXEC.BAT or autostart file of the PC.

#### 4.4.8 Automatic Alignment

The parameters set in this screen define the conditions under which an automatic alignment is performed with the SLS20-A or SLS40-A.

If the "Intervall" option is selected, an automatic alignment is performed every 1 hour, 3 hours, 6 hours, 12 hours or 24 hours depending on the user's selection. It is recommended to select this option. A shorter period is recommended for a more unstable setup.

If the "Threshold" option is selected, an automatic alignment is performed if the average intensity of the two (SLS40(-A): main) channels falls below the threshold specified in the connected window. It is recommended to select this option in addition to the "Intervall" option with a threshold of around 300 digits or 1/3 of the initial beam intensity whatever is lower (example only).

In the lower window, you also must select a period during which the signal must fall below this threshold to initiate an alignment. Usually, a 1 min period is ideal. However, if there are frequent obscurations of the beam (e.g. by persons) it might be recommended to select a longer period to avoid unnecessary re-alignments.

If you select the "Alignment At Beginning" option, an automatic alignment is always performed when you start a measurement.

### 4.5 View Data pull-down menu

#### 4.5.1 Graphics

With the Graphics submenu you can plot graphs of measured turbulence, crosswind and OEBMS1 data (files with extension ".res" or ".oeb") on the monitor and on HP Laser Jet (PCL) compatible printers.

To view or print the data, proceed as follows:

1. Select the path, name and type of the file to be printed in the "File Name" window ("SLS" = SLS20(-A)/SLS40(-A) data, "OEB" = OEBMS1 data).
2. In the window below, select the parameter to be viewed.
3. If you would like to view or print data from the whole period of the file with automatic vertical scaling, select the "Automatic Scaling" option. If you would like to select a certain time period and data range, specify period and range in the "From" and "To" windows.
4. Define the value in the "Minimum Nok (%)" window. For example, if you enter, the value 50, only those points will be considered which are from data

periods containing 50% error-free diagnosis data periods. If you enter the value 0, all points will be included.

5. Select OK. The graph will be displayed on the screen.
6. To print the data, press <F4>. Then enter the desired relative size of the print in %.

#### **4.5.2 Editor**

Selecting this subcommand invokes the text editor specified in the file SLSEEDIT.INI for easy viewing and editing data files.

##### **Example:**

When you are using MS-DOS (Version 5.00 up), the MS-DOS-Editor in the C:\DOS directory is called if the SLSEEDIT.INI contains the string: C:\DOS\EDIT.COM

## **4.6 Performing a measurement**

### **4.6.1 Starting a measurement**

To start a measurement, go into the Main pull-down menu of the main menu and select the "Start Measurement" subcommand.

The measured data will be written in files the names of which were defined in the Settings / Output submenu. If one of these names already exists, you will be prompted. You may then instruct the program to either append the data to the existing file, overwrite the existing file, or cancel to choose other file names.

### **4.6.2 Real time data display and graphics**

In the measurement mode, you can toggle between up to 5 tabulated output screens and 12 graphical output screens.

Tabulated output screens:

- Turbulence Data Unstable Stratification (Day)
- Turbulence Data Stable Stratification (Night)
- Diagnosis Data
- Extra Channel Data (only if extra channels are sampled)

- OEBMS1 Energy Balance Data (in OEBMS1 mode only)

Graphical output screens:

- Structure function constant of refractive index  $C_n^2$
- Inner scale of refractive index  $\ell_0$
- Structure function constant of temperature  $C_T^2$
- Dissipation rate of turbulent kinetic energy  $\epsilon$
- Sensible heat flux
- Momentum flux
- Monin-Obukhov length
- Crosswind (in crosswind mode only)
- Global radiation (in OEBMS1 mode only)
- Net radiation (in OEBMS1 mode only)
- Soil heat flux (in OEBMS1 mode only)
- Latent heat flux (in OEBMS1 mode only)

Switch between the tabulated and graphical modes by pressing the <Space> key. Within the tabulated and graphical modes you toggle from screen to screen with the <Page down> and <Page up> keys. The measurements will not be interrupted.

Data will be written to the tabulated output screens at the end of each main data period. A description of the displayed data follows.

### **Turbulence Data Unstable Stratification (Day):**

Run: the number of the main data period - numbered consecutively from the beginning of the measurement.

Nok: the percentage of error-free diagnosis data periods within the main data period.

Time: the computer's internal time at the end of the main data period (= time at the end of the last diagnosis data period).

$C_n^2$ : structure function constant of refractive index fluctuations in unit  $10^{-12} \text{ m}^{-2/3}$

$\ell_0$ : the inner scale of refractive index fluctuations in unit mm.

$C_T^2$ : the structure function constant of temperature fluctuations in unit  $\text{K}^2 \text{ m}^{-2/3}$ .

Diss: the rate of turbulent kinetic energy dissipation  $\varepsilon$  in unit  $\text{m}^2/\text{s}^3$ .

Heat: the turbulent flux of sensible heat in unit  $\text{W}/\text{m}^2$  calculated using Monin-Obukhov similarity for unstable density stratification.

-Mom: the negative (or absolute value of the) turbulent flux of momentum in unit  $\text{N}/\text{m}^2$  calculated using Monin-Obukhov similarity for unstable density stratification.

MO-L: the Monin-Obukhov length L in unit m calculated using Monin-Obukhov similarity for unstable density stratification.

Wind: Mean crosswind, i.e. the velocity component perpendicular to the optical propagation path in unit m/s (if crosswind output is selected in the Settings / Output submenu, with Crosswind Extension SLSCW-20 only)

At the bottom of the Turbulence Data tabulated output screens, the following additional information is shown:

- The current time and date
- The output file name (without extension)
- The efficiency of the data sampling. The sampling efficiency is defined as the fraction of the time used for data sampling within the sampling periods. The remaining time is used for calculations in the algorithms.

In the average over several diagnosis data periods, the efficiency should be between 80 and 100% if no crosswind is measured and between 60 and 100 % if crosswind is measured. To increase the sampling efficiency, select higher values in the "Calculation Step Turb." and "Calculation Step Wind" windows, and lower values in the "Iteration Depth Wind" window in the Settings / Advanced submenu (see Section 3.4.7).

- The free disk space on the active medium (hard disk)
- The available RAM space. If the displayed value is below 5 k and you are working in the SPC20 mode, the "Conversion Block Size" value in the Settings / Advanced submenu (see Section 3.4.7) should be slightly reduced.
- The air pressure used for the calculations. This is the pressure entered in the Settings / Path/Air submenu or the measured pressure if the SLSDMI-1 option is used.

- The air temperature used for the calculations. This is the temperature entered in the Settings / Path/Air submenu or the measured temperature if the SLSDMI-1 option is used.
- The difference between the air temperature and the near-surface temperature used for the determination of the heat flux sign if the SLSDMI-2 option is used (see below).

### **Turbulence Data Stable Stratification (Night):**

This screen is identical to the screen "Turbulence Data Unstable Stratification (Day)", however the turbulent fluxes Heat and -Mom and the Monin-Obukhov length MO-L were calculated for stable density stratification, respectively.

Due to the measurement principle, the instrument cannot decide if the stratification is unstable or stable. Therefore the results are always given for both cases in separate screens. The user must decide which of the data sets is the correct one for the given condition. Usually over land, the 'unstable' data must be taken at daytime and the 'stable' data must be taken at night.

In most cases, the transition between unstable and stable conditions can be identified by the connected minimum of the thermal turbulence, i.e. the minimum of  $C_n^2$ .

With the SLSDMI-2 option, the difference of the temperature at two heights (T2 - T1) is displayed and written to the output file. This defines the direction of the heat flux: with T1 corresponding to the higher and T2 to the lower thermometer, a negative value means stable conditions and downwards (negative) heat flux, and a positive value means unstable conditions and upwards (positive) heat flux.

### **Diagnosis Data:**

The Diagnosis Data screen displays basic statistics and error and warning codes for the diagnosis data periods. It allows a deeper understanding of the measurements and can be used to analyse problems. Most of the data given here are also contained in the diagnosis file ".dgn".

On the diagnosis screen, a data set is displayed at intervals of the diagnosis data period. Each data set contains the following data:

Sub: the consecutive number of the diagnosis data period within the main data period. With selected Auto Background mode, a "0" means a background cycle.

Data: the number of data points evaluated within the diagnosis data period.

<X>: average signal in channel 1 after background, crosstalk and AD range corrections.

<Y>: average signal in channel 2 after background, crosstalk and AD range corrections.

sigX: standard deviation of the signal in channel 1 after background, crosstalk and AD range corrections.

sigY: standard deviation of the signal in channel 2 after background, crosstalk and AD range corrections.

Cor: correlation of the signals in channel 1 and channel 2 after background, crosstalk and AD range corrections.

Xmin: the smallest detected signal level in channel 1.

Xmax: the largest detected signal level in channel 1.

Ymin: the smallest detected signal level in channel 2.

Ymax: the largest detected signal level in channel 2.

erX: error or warning code for channel 1 (see Appendix E)

erY: error or warning code for channel 2 (see Appendix E)

erW: error code for extensions (see Appendix E)

Note that all levels are given in digits, according to the 12 bit AD converter in the range 0 to 4095.

With the SLS40(-A), channel 1 refers to channel 1A and channel 2 refers to channel 2A.

At the bottom of the screen, the following additional information is displayed:

**Uncorrected data:**

<X>: average signal in channel 1 before background, crosstalk and AD range corrections.

<Y>: average signal in channel 2 before background, crosstalk and AD range corrections.

sigX: standard deviation of the signal in channel 1 before background, crosstalk and AD range corrections.

sigY: standard deviation of the signal in channel 2 before background, crosstalk and AD range corrections.

Cor: correlation of the signals in channel 1 and channel 2 before background, crosstalk and AD range corrections.

**Background data:**

<X>: average background signal in channel 1 used for the background and crosstalk corrections.

<Y>: average background signal in channel 2 used for the background and crosstalk corrections.

sigX: standard deviation of the background signal in channel 1 used for the background and crosstalk corrections.

sigY: standard deviation of the background signal in channel 2 used for the background and crosstalk corrections.

Cor: correlation of the background signals in channel 1 and channel 2 used for the background and crosstalk corrections.

**Vibration Index (SLS40(-A) only):**

This is a value quantifying the relative intensity variation caused by transmitter vibration. Values around 0 mean no or a negligible vibration effect and values above 0.5 mean a strong vibration effect. Due to its relative character, it is more likely to observe a high vibration index when the turbulence level is low. If error codes 8 or larger are displayed for erX or erY, a high vibration index may be the reason of other disturbances. A larger vibration index may also occur at large inner scale values (10 mm or more).

**Crosswind Flash:**

Instantaneous value of cross windspeed. This value is not averaged and therefore fluctuates strongly (Crosswind Extension SLSCW-20 only).

Position of beam as set by the automatic alignment (on the right side, SLS20-A/SLS40-A only):

"Beam distance" is the distance of the beam from the central position in percent of the possible scan range. 0% means that the beam is in the centre while values close to 100% mean that the beam reached to outer area of the scan cone. To be prepared for possible future drifts of the setup, you should perform a manual re-alignment of the transmitter if the beam distance approaches values of 80-100%.

"Beam angle" is the angle of the beam displacement from the centre, given in degrees (0-360°).

**Extra Channel Data:**

The extra channel input of the SPC20 card or SPU20 processing unit can read up to 11 voltages between 0 and 10 V which are displayed and stored by SLSRUN.

The extra channel calibration is contained in a file named "slsxchan.dat" as described in Appendix F.

In the upper part of the extra channel screen, average values are tabulated. A data set is displayed and stored at the end of every main data output period.

At the bottom of the extra channels data screen, the standard deviations, the minimum and the maximum values are also given for each channel.

**OEBMS1 Energy Balance Data:**

This screen displays the data measured by the additional sensors of the OEBMS1 extension, i.e. the global radiation, the net radiation and the soil heat flux, as well as the calculated latent heat flux.

Run: the number of the main data period - numbered consecutively from the beginning of the measurement.

Nok: the percentage of error-free diagnosis data periods within the main data period.

Time: the computer's internal time at the end of the main data period (= time at the end of the last diagnosis data period).

GlbRad: the global radiation measured with the pyranometer in unit  $W/m^2$ .

NetRad: the net radiation measured with the pyrrometer in unit  $W/m^2$ . Positive sign means downward radiation.

Soil: the soil heat flux in unit  $W/m^2$ , averaged over the measurements of the 3 soil heat flux sensors. Positive sign means downward heat flux.

SensDay: the turbulent flux of sensible heat in unit  $W/m^2$  calculated using Monin-Obukhov similarity for unstable density stratification.

SensNight: the turbulent flux of sensible heat in unit  $W/m^2$  calculated using Monin-Obukhov similarity for stable density stratification.

LatDay: the turbulent flux of latent heat in unit  $W/m^2$  calculated for unstable density stratification using the energy balance formula  $NetRad = SensDay + Soil + LatDay$ .

LatNight: the turbulent flux of latent heat in unit  $W/m^2$  calculated for stable density stratification using the energy balance formula  $NetRad = SensNight + Soil + LatNight$ .

erO: Error code for OEBMS1 measurements and interface communication (see Appendix E).

At the bottom of the screen, the following additional information is displayed:

Soil1: the soil heat flux in unit  $W/m^2$ , measured with soil heat flux sensor #1. Positive sign means downward heat flux.

Soil2: the soil heat flux in unit  $W/m^2$ , measured with soil heat flux sensor #2. Positive sign means downward heat flux.

Soil3: the soil heat flux in unit  $W/m^2$ , measured with soil heat flux sensor #2. Positive sign means downward heat flux.

Cond1: the soil heat conductivity in unit  $W/(m K)$ , measured with soil heat flux sensor #1.

Cond2: the soil heat conductivity in unit  $W/(m K)$ , measured with soil heat flux sensor #1.

Cond3: the soil heat conductivity in unit  $W/(m K)$ , measured with soil heat flux sensor #3.

UpRad: the radiation in  $W/m^2$  measured with the upper surface of the pyrriometer. Positive sign means downward radiation.

LwRad: the radiation in  $W/m^2$  measured with the lower surface of the pyrriometer. Positive sign means downward radiation.

### **Graphical Data Output:**

On the graphical output screen, the last 600 data points are graphically displayed.

Invoking the display does not interrupt the measurement. You can toggle between the different with the <Page down> and <Page up> keys.

A data point will not be considered if it corresponds to a main data period which contains fewer error-free diagnosis data periods than specified in the "Minimum Nok for Plot in %" window in the Settings / Advanced submenu.

Since a scintillation measurement cannot decide whether the density stratification is unstable or stable, both the "unstable" data (heat flux upwards) and the "stable" data (heat flux downwards) are displayed for those quantities which have been derived using Monin-Obukhov similarity (sensible heat flux, momentum flux, Monin-Obukhov length) and for the latent heat flux which has been calculated using the sensible heat flux.

The graphs are initially autoscaled. The <Cursor down> and <Cursor up> keys can be used to scale the graphics manually. This is recommended especially to remove spikes from the screen which may sometimes results from disturbed optical flux measurements. Rescaling is done by repeatedly pressing the <Cursor down> or <Cursor up> key. You switch back to autoscaling by pressing the <F1> key.

Note that only such points are plotted which are within the displayed range, so make sure to display all significant points by appropriate scaling.

### 4.6.3 Terminating a measurement

You terminate a measurement by pressing the <Esc> key. When you are prompted to verify, confirm with <Y>. The program then returns to the main menu.

## 4.7 Description of SLSRUN Version 2 output file formats

This chapter describes the output file formats of the

- main data output file (extension ".res")
- diagnosis data output file (extension ".dgn")
- extra channel data output file (extension ".xtr")
- covariance data output file (extension ".cov")
- raw data output file (extension ".raw")
- OEBMS1 data output file (extension ".oeb")

### 4.7.1 Main data output file

Each data set consists of one line containing the following quantities in the following order:

Run: the consecutive numbering of all main data periods starting from the beginning of the measurement.

Date: the computer's internal date at the end of the main data period.

Time: the computer's internal time at the end of each main data period.

Pressure: the air pressure in hPa used for the calculations. This is the pressure

entered in the Settings / Path/Air submenu or the measured pressure if the SLSDMI-1 option is used. The calculations of the structure function constant of temperature, the dissipation rate of turbulent kinetic energy, the sensible heat flux, the momentum flux, and the Monin-Obukhov length are based on this value.

Temperature: the air temperature in centigrade used for the calculations. This is the temperature entered in the Settings / Path/Air submenu or the measured temperature T1 if the SLSDMI-1 option is used. The calculations of the structure function constant of temperature, the dissipation rate of turbulent kinetic energy, the sensible heat flux, the momentum flux, and the Monin-Obukhov length are based on this value.

Temperature difference: The difference between the air temperature and the near-surface temperature which can be used for the determination of the heat flux sign with the SLSDMI-2 option.

Path length: The length of the optical propagation path in meters as entered in the Settings / Path submenu. The calculations of all output parameters depend on this value.

Height: the measurement height in meters as entered in the Settings / Path submenu. The calculations of the sensible heat flux, the momentum flux and the Monin-Obukhov length are based on this value.

siglogX: the standard deviation of the logarithm of the amplitude in channel 1 calculated from the measured intensity data. All further calculations are based on this value.

siglogY: the standard deviation of the logarithm of the amplitude in channel 2 calculated from the measured intensity data. All further calculations are based on this value.

logCor: the correlation of the logarithms of the amplitude in channels 1 and 2 calculated from the measured intensity data. All further calculations are based on this value.

Nok: the percentage of error free diagnosis data periods within the main data period.

$C_n^2$ : the structure function constant of refractive index fluctuations in  $10^{-12} \text{ m}^{-2/3}$ .

$\ell_0$ : the inner scale of refractive index fluctuations in mm.

$C_T^2$ : the structure function constant of temperature fluctuations in  $\text{K m}^{-2/3}$ .

Diss: the rate of kinetic energy dissipation in unit  $\text{m}^2/\text{s}^3$ .

Heat day: the turbulent flux of sensible heat in unit  $\text{W}/\text{m}^2$  calculated using Monin-Obukhov similarity for unstable density stratification ("Day").

Heat night: the turbulent flux of sensible heat in unit  $W/m^2$  calculated using Monin-Obukhov similarity for stable density stratification ("Night").

Mom day: the absolute value of turbulent flux of momentum in unit  $N/m^2$  calculated using Monin-Obukhov similarity for unstable density stratification ("Day").

Mom night: the absolute value of the turbulent flux of momentum in unit  $N/m^2$  calculated using Monin-Obukhov similarity for stable density stratification ("Night").

MO-L day: the Monin-Obukhov length  $L$  in unit  $m$  calculated using Monin-Obukhov similarity for unstable density stratification ("Day").

MO-L night: the Monin-Obukhov length  $L$  in unit  $m$  calculated using Monin-Obukhov similarity for stable density stratification ("Night").

Wind: Mean crosswind, i.e. the velocity component perpendicular to the optical propagation path in unit  $m/s$  (if crosswind output is selected in the Settings / Output submenu, with Crosswind Extension SLSCW-20 only)

#### 4.7.2 Diagnosis data output file

If the "Save Diagnosis Data" option is selected in the Settings / Output submenu, a diagnosis file is created during the measurement.

Each data set of the diagnosis file consists of one line and is given for every diagnosis data period. It contains the following quantities in the following order:

Run: the number of the main data period - numbered consecutively from the beginning of the measurement.

Sub: the number of the diagnosis data period within the main data period. With selected Auto Background mode, a "0" means a background cycle.

Data: the number of data points evaluated within the diagnosis data period.

<Xu>: average signal in channel 1 before background, crosstalk and AD range corrections.

<X>: average signal in channel 1 after background, crosstalk and AD range corrections.

<Yu>: average signal in channel 2 before background, crosstalk and AD range corrections.

<Y>: average signal in channel 2 after background, crosstalk and AD range corrections.

sigXu: standard deviation of the signal in channel 1 before background, crosstalk and AD range corrections.

sigX40: as sigXu in SLS20 mode, with correction for transmitter vibration in SLS40 mode

sigX: standard deviation of the signal in channel 1 after additional background, crosstalk and AD range corrections.

sigYu: standard deviation of the signal in channel 2 before background, crosstalk and AD range corrections.

sigY40: as sigYu in SLS20 mode, with correction for transmitter vibration in SLS40 mode

sigY: standard deviation of the signal in channel 2 after additional background, crosstalk and AD range corrections.

Coru: correlation of the signals in channel 1 and channel 2 before background, crosstalk and AD range corrections.

Cor40: as Coru in SLS20 mode, with correction for transmitter vibration in SLS40 mode

Cor: correlation of the signals in channel 1 and channel 2 after additional background, crosstalk and AD range corrections.

Xmin: the smallest detected signal level in channel 1.

Xmax: the largest detected signal level in channel 1.

Ymin: the smallest detected signal level in channel 2.

Ymax: the largest detected signal level in channel 2.

erX: error or warning code for channel 1 (see Appendix E)

erY: error or warning code for channel 2 (see Appendix E)

erW: error code for extensions (see Appendix E)

### 4.7.3 Extra channel data output file

If one or more additional input channels are sampled, an extra channel output file is created.

Each data block of the extra channel output file consists of four lines preceded by

one line with date and time and followed by one blank line. Each output data block refers to one main data period.

The output data block contains the following data in the following order:

Line 0:

Date: The computer's internal date at the measurement

Time: The computer's internal time at the end of the main data period

Line 1:

The average of each channel beginning with extra channel 1.

Line 2:

The standard deviation of each channel beginning with extra channel 1.

Line 3:

The smallest measured value of each channel beginning with extra channel 1.

Line 4:

The largest measured value of each channel beginning with extra channel 1.

The values are calibrated as defined in the file "slsxchan.dat". For a description see Appendix F.

#### 4.7.4 Covariance data output file

If the "Save Covariance Data" option is selected in the Settings / Output submenu, a file containing the time lagged crosscorrelation data is created during the measurement (SLSCW-20 option only).

Each data block of the covariance data file consists of 56 lines preceded by one line with date and time and followed by one blank line. Each data block is generated every 1-5 seconds.

The covariance data output block contains the following data in the following order:

Line 0:

Date: The computer's internal date at the end of the sampling period

Time: The computer's internal time at the end of the sampling period

FlashW: The crosswind velocity (flash) in unit m/s calculated from the covariances.

Line 1:

Timlag0: The value 0.000 (corresponding to the time-lag 0)

VarX0: The variance of channel 1 with time-lag 0

VarY0: The variance of channel 2 with time-lag 0

Line  $i$  ( $i = 2$  to  $56$ ):

Timlag $i$ : The time-lag  $i$  divided by the conversion time

CovXi: The covariance between channel 1 and the time-lagged channel 2

CovY $i$ : The covariance between channel 2 and the time-lagged channel 1

Covariance data output files cannot be generated if the SPU20 processing unit is used.

#### 4.7.5 Raw data output file

If the "Save Raw Data" option is selected in the Settings / Output submenu, a file containing the digital raw data is created during the measurement.

Each raw data output block consists of a number of lines which corresponds to the selected Conversion Block Size (see Section 4.6) preceded by one line with date and time and followed by one blank line. A data block is sampled over a period of 1-5 s, however it needs much more time to write the data to the disk. Therefore the sampling efficiency is seriously reduced if raw data are taken. Each raw data output block contains the following data in the following order:

Line 0:

Date: The computer's internal date at the end of the sampling period.

Time: The computer's internal time at the end of the sampling period.

Run: the number of the main data period - numbered consecutively from the beginning of the measurement.

Sub: the number of the diagnosis data period within the main data period. With selected Auto Background mode, a "0" means a background cycle.

All following lines of the block:

ADX: Level in channel 1 (0 to 4095)

ADY: Level in channel 2 (0 to 4095)

Raw data output files cannot be generated if the SPU20 processing unit is used.

#### 4.7.6 OEBMS1 data output file

In the OEBMS1 mode, a file containing the energy balance component data is created during the measurement.

Each data set consists of one line containing the following quantities in the following order:

Run: the number of the main data period - numbered consecutively from the beginning of the measurement.

Date: the computer's internal date at the end of the main data period.

Time: the computer's internal time at the end of the main data period.

Nok: the percentage of error-free diagnosis data periods within the main data period.

GlbRad: the global radiation measured with the pyranometer in unit  $W/m^2$ .

NetRad: the net radiation measured with the pyrrometer in unit  $W/m^2$ . Positive sign means downward radiation.

Soil: the soil heat flux in unit  $W/m^2$ , averaged over the measurements of the 3 soil heat flux sensors. Positive sign means downward heat flux.

SensDay: the turbulent flux of sensible heat in unit  $W/m^2$  calculated using Monin-Obukhov similarity for unstable density stratification.

SensNight: the turbulent flux of sensible heat in unit  $W/m^2$  calculated using Monin-Obukhov similarity for stable density stratification.

LatDay: the turbulent flux of latent heat in unit  $W/m^2$  calculated for unstable density stratification using the energy balance formula  $NetRad = SensDay + Soil + LatDay$ .

LatNight: the turbulent flux of latent heat in unit  $W/m^2$  calculated for stable density stratification using the energy balance formula  $NetRad = SensNight + Soil + LatNight$ .

Soil1: the soil heat flux in unit  $W/m^2$ , measured with soil heat flux sensor #1. Positive sign means downward heat flux.

Soil2: the soil heat flux in unit  $W/m^2$ , measured with soil heat flux sensor #2. Positive sign means downward heat flux.

Soil3: the soil heat flux in unit  $W/m^2$ , measured with soil heat flux sensor #3. Positive sign means downward heat flux.

Cond1: the soil heat conductivity in unit  $W/(m K)$ , measured with soil heat flux sensor #1.

Cond2: the soil heat conductivity in unit  $W/(m K)$ , measured with soil heat flux sensor #2.

Cond3: the soil heat conductivity in unit  $W/(m K)$ , measured with soil heat flux sensor #3.

UpRad: the radiation in  $W/m^2$  measured with the upper surface of the

pyrradiometer. Positive sign means downward radiation.

LwRad: the radiation in  $W/m^2$  measured with the lower surface of the pyrradiometer. Positive sign means downward radiation.

erO: Error code for OEBMS1 measurements and interface communication (see Appendix E).

## 4.8 Utilities pull-down menu

### 4.8.1 Recalculate Turbulence Data Utility

#### **Purpose:**

The real time calculations of SLSRUN are based on certain values for temperature, pressure, optical path length and measurement height which were entered in the menu before the measurement started.

Since after the measurement, there is often more information about these parameters available, it is sometimes desirable to recalculate the derived results. This is performed by the utility Recalculate Turbulence Data. It computes  $C_n^2$ ,  $\ell_0$ ,  $C_T^2$ , Diss, M, H and L from log-amplitude standard deviations and correlations for arbitrary values of pressure, temperature, path length and measurement height.

#### **Use:**

In order to use the Recalculate Turbulence Data utility you must edit the SLSRUN output data file (see Editor, Section 3.5.2). Change the parameters you want to modify (changes of temperature, pressure, optical path length and measurement height allowed). Each modification is valid only for one data set. Use the replace command of the editor for larger changes.

Then call the Recalculate Turbulence Data utility. Specify the names of the data file you have edited (must be on the active directory) and the file where the recalculated data should be written to. The format of the two files will be identical, so the resulting file can again be edited and subject to a recalculation with the Recalculate Turbulence Data utility.

Note that due to rounding errors, the original data and the recalculated data may differ slightly even for the same parameter set.

## 4.8.2 Increase Averaging Time utility

### Purpose:

The Increase Averaging Time utility reduces the data rate of SLSRUN main data output files by an averaging procedure. The program may be used to improve the statistical significance of the results or to adapt the data rate to that of other instruments.

The averaging procedure is an arithmetic mean applied to the optical signal variances and covariances. This means there will be no difference in the results if the data is taken with an original rate of, say, 10 minutes or if the data is taken with an original rate of 1 minute and then is averaged with the Increase Averaging Time utility over 10 minutes.

It is therefore recommended to measure the data with a higher data rate in the case of doubt and average later if desired. In this way you keep full flexibility.

### Use:

Call the Increase Averaging Time utility. Specify the name of the original output file (must be on the active directory) and that of the new output file for the averaged data.

To remind you about the time structure of the data, the times of the first ten data points are displayed. Then you are asked for the number of data points to be averaged. For example if the SLSRUN main data output file has a 2 minute data rate, enter a number of 5 to produce a 10 minute data rate. The program also asks you for the number of data points to be skipped at the beginning. This makes it possible to match the timing of other measurements or to obtain data, say, at flat 10 minute intervals.

Skipped data points at the beginning and remaining data points at the end of the file are rejected.

As with the original file, the times given in the new file are those of the ends of the data periods. The format of the new data file is the same as that of the original file. The new data file can be viewed with SLSRUN or treated with the Recalculate Turbulence Data or the  $C_n^2$  Height Profiles utilities.

### 4.8.3 Suppress Errors utility

#### **Purpose:**

The Suppress Errors utility regenerates SLSRUN main data output files from SLSRUN diagnosis files. In this procedure the recognition of individual error messages can be suppressed.

In order to understand the idea of the Suppress Errors utility, remember that the criteria for error messages in the SLSRUN program are quite strict. This ensures a high reliability of the stored data, but under certain conditions, like misalignment or "heavy" insect flight, longer periods without any data can result. Sometimes, one might prefer to have data of a lower quality rather than to have no data at all.

#### **Use:**

In order to recover the data with suppressed errors, first look into the diagnosis file and see which error messages are responsible for the loss of data. Try to figure out the physical reason like rain, fog, insects, misalignment, dirty windows or low signal-to-noise ratio (SNR). Some of the reasons like insect flight or misalignment may allow a certain data recovery. With other reasons like rain there is hardly any hope to create meaningful results with the Suppress Errors utility. Note also that under conditions of laminar flow in calm and clear nights, poor-SNR (and other) error codes indicate that there is no turbulence and therefore the zeros in the main data output file have physical meaning.

Be careful and conservative in the selection of the error messages you want to suppress, always keeping in mind that there was a reason for each code to occur. Try to select only a small number, possibly only one or two different codes. If a code preferably occurs in one channel, you should suppress this message only there.

Verify that the SLSRUN diagnosis file, the SLSRUN main data output file and the correct calibration data file SLSCAL.XXX are on the directory from which you start the Suppress Errors utility (active directory). Specify the name of the diagnosis file and that of the new output file. Sum up the error codes you want to suppress independently for each channel and enter these sums when you are asked. Enter 0 if you just want to recover lost data.

The new output file has the same format as the original output file and can be viewed with SLSRUN or treated with the Recalculate Turbulence Data, Increase Averaging Time or  $C_n^2$  Height Profiles utilities. Note that due to rounding errors (the diagnosis file contains only a limited number of digits) small deviations between the original output file and the regenerated file may occur even if no error suppression was performed.

If errors were suppressed, make plausibility tests of the regenerated data and use them with care.

#### 4.8.4 $C_n^2$ Height Profiles utility

##### **Purpose:**

The  $C_n^2$  Height Profiles utility calculates height profiles of the structure function constant  $C_n^2$  and the inner scale  $\ell_0$  of refractive index fluctuations from main data output files. The calculation is based on Monin-Obukhov similarity.

##### **Use:**

Start the  $C_n^2$  Height Profiles utility and specify the names of the input and output files (in the active directory). The input file must have the format of the SLSRUN main data output files.

The new file will contain the following data [units in brackets]:

Line 1:  
Date, Time

Lines 2 to 39:  
height [m]  $C_n^2$  day  $C_n^2$  night [ $\text{m}^{-2/3}$ ]  $\ell_0$  day  $\ell_0$  night [mm]

Line 40:  
blank

"Day" and "Night" stand for unstable and stable density stratification respectively. According to the given situation either the first or the second value for  $C_n^2$  or  $\ell_0$  applies.

The profiles are given at 38 height levels (above ground) between 0.5 and 300 m. The values at greater heights are only valid if the boundary layer has a sufficient vertical extent. The upper height limit is much lower than 300 m under the following conditions:

1. in the first few hours after sunset or sunrise.
2. at night, especially at low wind velocities.
3. during winter days.

4. if the cloud cover is large and the wind velocity is low.

#### **4.8.5 Convert Data Format utility**

##### **Purpose:**

In the SLSRUN Version 2 main data output file, one data set contains more than 80 characters in a single line. If you would like to view or print the data, it might be necessary to convert the data to a format with lines having less than 80 characters. This is done by the Convert Data Format utility. It transforms the SLSRUN Version 2 main data output file into a 3-line format. The order and the formats of the individual data remains unchanged.

##### **Use:**

Call the Convert Data Format utility and enter the name of the file to be transformed (must be in the active directory).

#### **4.8.6 The program SLSFIL**

##### **Purpose:**

The program SLSFIL generates the path calibration data files used by SLSRUN Version 2 and named SLSCAL.XXX, where XXX stands for the optical propagation path length. For each propagation path length used, a separate file is used.

With the SLSRUN Version 2 software, the calibration files for path lengths between 50 and 300 m are provided in steps of 1 m. If a path length outside this range is selected, you will first have to generate the calibration file with the SLSFIL program.

##### **Use:**

Exit SLSRUN and execute SLSFIL by entering the DOS command SLSFIL<Return>. You are then asked to specify the output file name. Enter SLSCAL.XXX, where XXX is the path length in meters (e.g. SLSCAL.260 for 260 m and SLSCAL.45 for 45 m).

Then you are asked to specify the accuracy desired. If you do not have a very fast computer we recommend the selection of the standard option. The accuracy is already quite high.

Note: Extensive numerical integrations are performed. Depending on your computer speed, the calculation of path calibration data may take several hours even in the standard mode.

After the new path calibration file was created, verify that it is on the SLSRUN working directory.

## Appendix A Theory

This appendix summarizes the mathematical formulae used by the programs SLSRUN, SLSREC and SLSFIL.

If radiation of wavelength  $\lambda$  and wavenumber  $K = 2\pi/\lambda$  is emitted from two sources, which are separated by a distance  $d$  perpendicular to the propagation direction, and this radiation is independently observed by two detectors of diameter  $D$ , which are separated by the same distance  $d$  with the separation vectors pointing in the same direction (parallel paths), the covariance of the logarithm of the amplitude of the received radiation is given by

$$B_{12} = 4\pi^2 K^2 \int_0^R dx \int_0^\infty d\kappa \kappa \phi_n(\kappa) J_0(\kappa d) \sin^2 \left[ \frac{\kappa^2 x (R-x)}{2KR} \right] \frac{4J_1^2(\kappa D x / 2R)}{(\kappa D x / 2R)^2}, \quad (1)$$

where  $R$  is the propagation path length,  $x$  is the coordinate along the propagation path,  $\phi_n$  is the three-dimensional spectrum of the refractive index inhomogeneities and  $J_0$  and  $J_1$  are Bessel functions of the first kind. Eq. (1) is valid as long as scattering is weak, i. e. as long as  $B_{12} < 0.3$ . Otherwise saturation occurs. In this case the measured  $B_{12}$  is smaller than that predicted by Eq. (1).

With  $d = 0$ , Eq. (1) also provides the expression for the variances  $B_1$  and  $B_2$  at the single detectors.

The inner integral of Eq. (1) is the path weighting function. The path weighting functions of the variances and covariances for a 100 m propagation distance and values of the inner scale  $\ell_0$  of 2mm, 4mm and 10mm are given in Figs. A.1 and A.2.

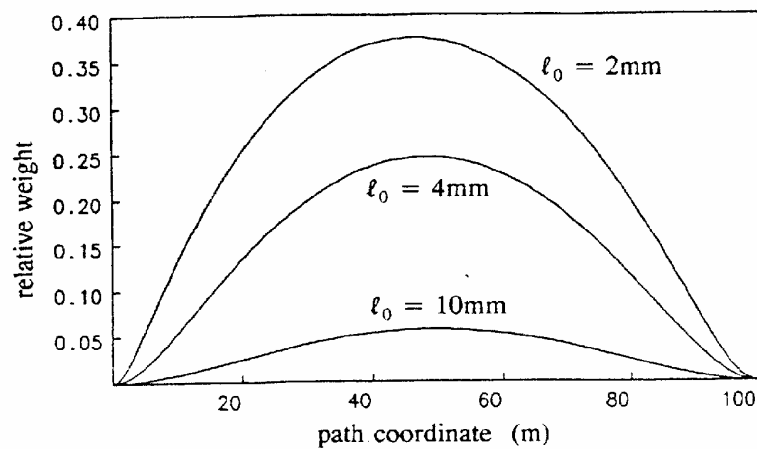

**Figure A.1:** Path weighing functions (100 m path)

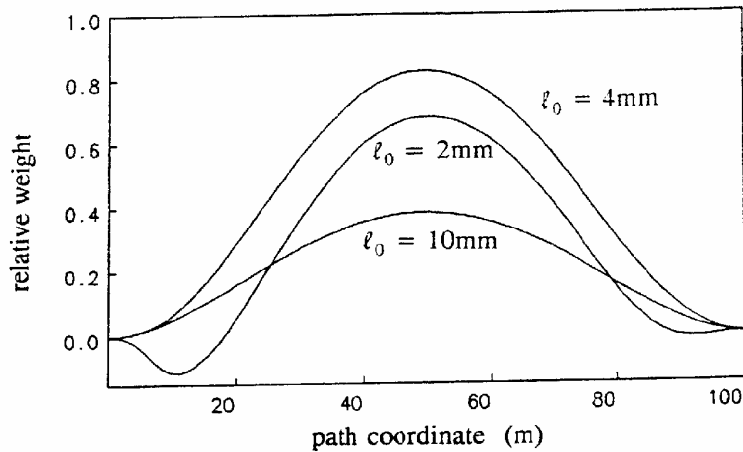

**Figure A.2:** Path weighting functions (100 m path)

The function  $\phi_n$  has the form

$$\phi_n(\kappa) = 0.033C_n^2\kappa^{-11/3}f_\phi(\kappa\ell_0), \quad (2)$$

where  $C_n^2$  is the structure function constant of refractive index in the inertial subrange of turbulence and  $f_\phi(\kappa\ell_0)$  is a function describing the decay of refractive index fluctuations in the dissipation range. The model of Hill is assumed for  $f_\phi$ .

Inserting Eq. (2) into Eq. (1) defines the covariance and the variances if  $C_n^2$ ,  $\ell_0$  and the physical dimensions of the instrument are known. Hence measurements of  $B_{12}$  and  $B_1$  or  $B_2$  can be used to derive  $C_n^2$  and  $\ell_0$ . Note that the correlation coefficient  $r = B_{12}/(B_1B_2)^{1/2} = B_{12}/B_1 = B_{12}/B_2$  is a function of  $\ell_0$  only. For a 100 m long path this relationship is given in Fig. A.3.

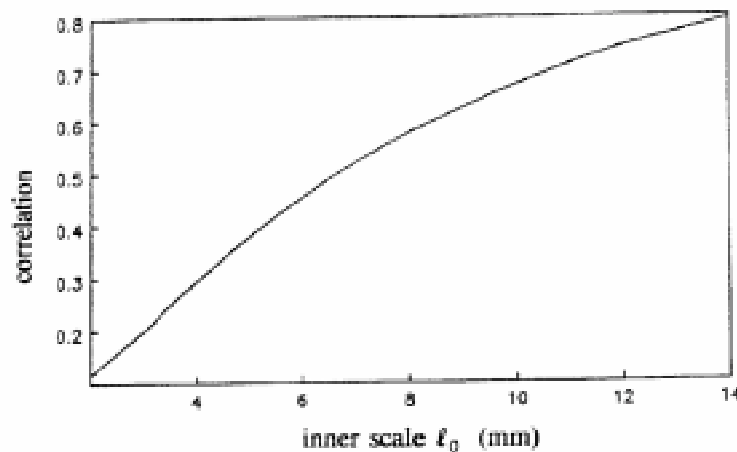

**Figure A.3:** Correlation versus inner scale  $\ell_0$

Note also that the variances  $B_1$  and  $B_2$  are not only proportional to  $C_n^2$ , but they also depend on  $\ell_0$ . These dependencies are contained in the files SLSCAL.XXX.

Since variances of intensity  $\sigma_i^2$  are measured rather than variances of log-amplitude  $B_i$ ,  $\sigma_i^2$  must be converted into  $B_i$ . For log-normally distributed amplitude one can apply the relation

$$B_i = \frac{1}{4} \log \left( 1 + \frac{\sigma_i^2}{\langle I_i \rangle^2} \right). \quad (3)$$

From  $C_n^2$  the structure function constant of temperature  $C_T^2$  can be calculated via

$$C_T^2 = C_n^2 T^4 (ap)^{-2}, \quad (4)$$

where  $T$  is the air temperature in Kelvin and  $p$  is the air pressure in hPa (mbar). The constant  $a$  is given by  $7.89 \cdot 10^{-5}$  K/hPa at 670 nm wavelength.

Eq. (4) neglects the contribution of humidity fluctuations. In the presence of humidity fluctuations a small error occurs. By use of similarity arguments, the error of  $C_T$  (and that of the later derived heat fluxes) can be estimated to be 3% times the inverse Bowen ratio (latent heat flux divided by sensible heat flux). Note that the error is quite exactly half as large as the humidity error of ultrasonic thermometers.

The inner scale  $\ell_0$  is closely related to the dissipation rate of the kinetic energy of turbulence  $\varepsilon$ :

$$\varepsilon = \nu^3 (7.4 / \ell_0)^4. \quad (5)$$

Here  $\nu$  is the kinematic viscosity of air which can be calculated in m<sup>2</sup>/s via

$$\nu = [1.718 + 0.0049(T - 273.15)] \rho^{-1} \cdot 10^{-5}, \quad (6)$$

if  $T$  is the temperature in K and  $\rho$  is the air density in kg/m<sup>3</sup>.

From  $C_T^2$  and  $\varepsilon$ , the turbulent kinematic fluxes of heat  $Q_0$  (unit K m/s) and momentum  $-u_*^2$  (unit m<sup>2</sup>/s<sup>2</sup>) can be computed by use of Monin-Obukhov similarity. If  $T_* = -Q_0 / u_*$  is the turbulent temperature scale,  $L = T_* u_*^2 / (kg T_*)$  is the Monin-Obukhov length,  $z$  is the height above ground,  $k = 0.4$  is the von Karman constant,  $g = 9.81$  m/s<sup>2</sup> is the gravitational acceleration, and  $\beta_1 = 0.86$  is the Obukhov-Corrsin constant, then the following semi-empirical expressions have proven a quite high accuracy:

$$C_T^2(kz)^{2/3} T_*^{-2} = 4\beta_1 \left( 1 - 7 \frac{z}{L} + 75 \left( \frac{z}{L} \right)^2 \right)^{-1/3} \quad (7)$$

and

$$\epsilon k z u_*^{-3} = \left( 1 - 3 \frac{z}{L} \right)^{-1} - \frac{z}{L} \quad (8)$$

for  $z/L < 0$  (unstable), and

$$C_T^2(kz)^{2/3} T_*^{-2} = 4\beta_1 \left( 1 + 7 \frac{z}{L} + 20 \left( \frac{z}{L} \right)^2 \right)^{1/3} \quad (9)$$

and

$$\epsilon k z u_*^{-3} = \left( 1 + 4 \frac{z}{L} + 16 \left( \frac{z}{L} \right)^2 \right)^{-1/2} \quad (10)$$

for  $z/L > 0$  (stable).

Solving equations (7), (8), (9) and (10) for the turbulent fluxes requires a numerical iteration scheme.

The turbulent heat flux  $H$  with unit  $W/m^2$  and the turbulent momentum flux  $M$  with unit  $kg\ m^{-1}\ s^{-2}$  are calculated via the relations

$$H = -c_p \rho u_* T_* \quad (11)$$

and

$$M = -\rho u_*^2. \quad (12)$$

## Appendix B Description of the instruments

### B.1 Transmitter and receiver units

#### B.1.1 General

The transmitter and receiver units consist of the tubes and the positioning devices. The tubes contain optics and electronics.

The electronics in the transmitter unit produces the modulation signal. Hence it requires only DC voltage for operation.

The electronics in the receiver unit consists of signal amplifiers and voltage regulators. The modulated signals are then transferred through the line to the Junction/Control Box and further to the SPC20 card(s) or the SPU20 processing unit.

Both, transmitter and receiver have a heatable front glass to prevent ice or dew deposits (see Appendix B.2.1).

Do not open the transmitter or the receiver tubes since they will be difficult to re-adjust. An exception is the back-cover of the receiver, which must be opened to change the amplifier dip switch setting (see section B.1.4).

The only necessary maintenance to be performed by the user is the pinhole adjustment (see section B.1.3). Additionally, the user should regularly check the orientation of the tubes (see section B.1.2).

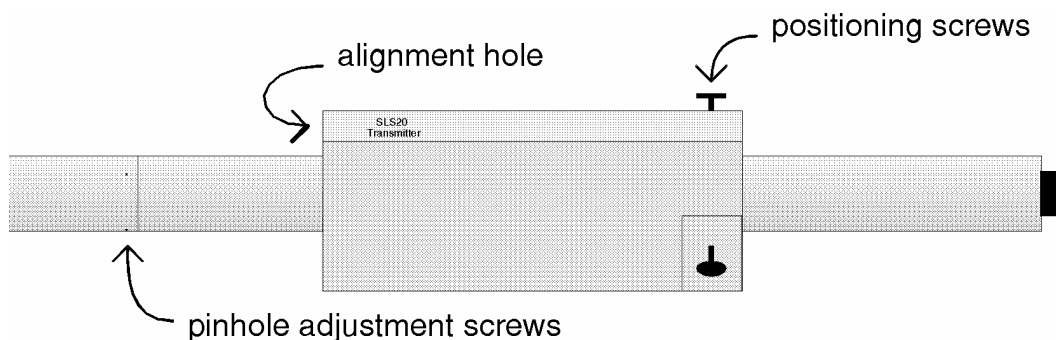

**Figure A.4:** SLS20 Transmitter Unit

### **B.1.2 Orientation of tubes**

Since the two beams are identified by their polarization direction, the orientation of the transmitter and receiver relative to each other must be coordinated. Therefore it is necessary that the tubes have the correct rotational orientation within the positioning devices. Make sure also that the units are well horizontally positioned during the operation. Otherwise a noticeable crosstalk between the two channels will be noticed (more than a few percent).

The correct orientations of the tubes within the positioning devices are as follows:

**Transmitter:** The source emits two beams. These two beams must lie exactly in a horizontal line. Check with a (sufficiently transparent) piece of paper covering the frontal window. If necessary, open the positioning screws and turn the tube until the position is correct.

It is also required that the "down" mark on the tube (black triangle on red ground) shows downwards. If the down mark of the transmitter shows upwards and that of the receiver shows downwards (or inverse), crossed paths (instead of parallel paths) would result and will produce wrong data.

**Receiver:** Near the back of the receiver tube there is a small screw near the "down" mark. This screw must exactly show down.

### **B.1.3 Pinhole adjustment**

After transportation, mechanical shock or strong temperature variations it might be necessary to re-adjust the spatial filter pinhole in the transmitter unit. It is recommended that a re-adjustment is made every time the instruments have been moved before the measurements start.

The three (small) pinhole adjustment screws are near the front end of the transmitter tube (see figure on the page before). Use two small screw drivers to perform the adjustment procedure as follows:

- a) Put a screen (piece of paper) in front of the instrument or point the laser beam to a white wall. Operate the lase, you will see two red spots (these spots overlap in a short distance).
- b) Loosen one of the pinhole adjustment screws a little (less than a quarter turn) and immediately follow with another screw by turning it in the opposite sense (tightening direction). You will notice the beam becoming more or less bright. Maximize the output intensity.
- c) Repeat this procedure iteratively with two other screws, always trying to achieve the maximum beam output, until no further improvement is possible.

**Caution: 1. Be very careful to never "lose" the beam. It is quite difficult to find it again. 2. Never loosen a screw without at the same time tightening another screw. The pinhole is fixed by the adjustment screws and may otherwise drop out.**

d) Tighten the pinhole by tightening one screw.

#### B.1.4 Amplifier dip switch setting

The SLS20(-A) / SLS40(-A) can be operated over different path lengths. Different path lengths go along with different radiation intensities. The dip switches in the back of the receiver tube allow the adaptation of the voltage output range.

In order to reach the dip switches, unplug the receiver, turn out the three Phillips screws at the back and carefully pull off the back cover. Be cautious not to tear off one of the cables. The dip switch is now visible.

SLS20(-A): The first 4 dip switches (1-4) belong to channel 1 and the second 4 dip switches (5-8) belong to channel 2.

SLS40(-A): The first 4 dip switches (1-4) of the upper row belong to channel 1A and the second 4 dip switches (5-8) of the upper row belong to channel 2A. The first 4 dip switches (1-4) of the lower row belong to channel 1B and the second 4 dip switches (5-8) of the lower row belong to channel 2B.

If "0" means position "off" (up) and "1" means position "on" (down) then the following dip switch positions typically correspond to the following ranges:

Switch	1	2	3	4	5	6	7	8	Path Length
Position	0	0	0	1	0	0	0	1	< 100 m (see Note)
	1	1	1	0	1	1	1	0	90 – 120 m (factory setting)
	0	0	1	0	0	0	1	0	110 – 150 m
	1	1	0	0	1	1	0	0	140 – 190 m
	0	1	0	0	0	1	0	0	170 – 220 m
	1	0	0	0	1	0	0	0	210 – 300 m

Note: For paths much shorter than 100 m, the mean level may be higher than the indicated range. If the fluctuating signal does not hit the upper range limit (4095 digits), this can be tolerated. If regularly hits or even continuously is at the upper range limit and you cannot make the path longer, the laser output power should be reduced. Contact the manufacturer or your local representative for details.

If for a well aligned set-up, the signal is too low or too high (and cannot be adjusted at the Junction/Control Box), use the next lower or higher dip switch setting, respectively.

With the SLS40(-A), the dip switch settings of the upper and lower row usually is identical.

### B.1.5 Source lifetime and operation temperature range

The SLS20(-A) / SLS40(-A) uses laser diodes as radiation sources which typically operate over more than 20.000 hours.

Laser diodes will be damaged or their lifetime will be decreased if they are operated at unfavourate temperatures. Therefore never operate the transmitter outside its given operation temperature range (see specifications in Appendix C). Make sure that the instrument is shielded from direct sun radiation on hot days. Also do not unattendedly operate the instrument when the temperature may drop below the lower temperature limit.

A damaged source emits a significantly reduced light intensity. In this case send the transmitter unit to the manufacturer for source replacement.

## B.2 Junction/Control Box

The Junction/Control Box connects the cables coming from the transmitter, receiver, PC or SPU20 processing unit, and from the external power supply. It also allows the control of the transmitter unit by the PC.

### B.2.1 Power supply

With the SLS20, the voltages for the transmitter and receiver can optionally be supplied by the PC or SPU20 processing unit (internal) or by external power supplies. An external power supply must always be used if the PC is not able to provide the currents needed (Laptop PC's usually do not).

If supply by the PC or the SPU20 processing unit is desired put the switch at the JCB to the "int" position. Otherwise put the switch to the "ext" position and connect the external power supply according to the JCB connection scheme in Appendix B.2.4, connector "power supply". **If the switch is in the middle position, both source and receiver are disconnected.**

With the SLS20-A, SLS40 and SLS40-A, supply by the PC or SPU20 processing unit is only possible if the cable length to the receiver or transmitter do not exceed the following lengths:

SLS20-A	cable to transmitter - 150 m
SLS40	cable to receiver - 50 m
SLS40-A	cable to transmitter - 150 m and cable to receiver - 50 m

If the cable length to the transmitter and/or receiver exceeds the cable lengths given above, an external power supply is required.

The PC or the external power supply must provide currents of

SLS20	100 mA at +12 V
	50 mA at -12 V
SLS20-A	500 mA at +12 to -18 V (required voltage, see below)
	150 mA at -12 to -18 V (required voltage, see below)
SLS40	350 mA at +12 to +18 V
	200 mA at -12 to -18 V
SLS40-A	550 mA at +12 to +18 V
	200 mA at -12 to -18 V

For external supply, the following operation voltages are required:

Model	Cable Lengths	Operation Voltage
SLS20	Up to 400 m to transmitter and up to 200 m to receiver	±12 V (18 V max.)
SLS20-A	Up to 150 m to transmitter and up to 200 m to receiver	±12 V (13.5 V max.)
	150 – 300 m to transmitter and up to 200 m to receiver	±16 V (17.6 V max.)
	300 – 400 m to transmitter and up to 200 m to receiver	±18 V (19.8 V max.)
SLS40	Up to 400 m to transmitter and up to 50 m to receiver	±12 V (18 V max.)
	Up to 400 m to transmitter and up 50 – 150 m to receiver	±16 V (18 V max.)
	Up to 400 m to transmitter and up 150 – 200 m to receiver	±18 V (19.6 V max.)
SLS40-A	Up to 150 m to transmitter and up to 50 m to receiver	±12 V (13.5 V max.)
	150 – 300 m to transmitter and up to 50 m to receiver	±16 V (17.6 V max.)
	300 – 400 m to transmitter and up to 50 m to receiver	±18 V (19.8 V max.)
	Up to 150 m to transmitter and 50 – 150 m to receiver	±16 V (17.6 V max.) <b>Attention: Set JCB Power Supply Jumper to “on” (see below)</b>
	150 – 300 m to transmitter and 50 – 150 m to receiver	±16 V (17.6 V max.)
	300 – 400 m to transmitter and 50 – 150 m to receiver	±18 V (19.8 V max.)
	Up to 150 m to transmitter and 150 – 200 m to receiver	±18 V (19.8 V max.) <b>Attention: Set JCB Power Supply Jumper to “on” (see below)</b>
	150 – 400 m to transmitter and 150 – 200 m to receiver	±18 V (19.8 V max.)

In the certain cases indicated above, the JCB Power Supply Jumper must be set to "on", otherwise it must be set to "off" (default). This is necessary to avoid a too high voltage at the transmitter in cases of a short transmitter cable and a long receiver cable.

To access the Power Supply Jumper, open the Junction/Control Box. The jumper position is defined in the following drawing:

JCB Power Supply Jumper "off"

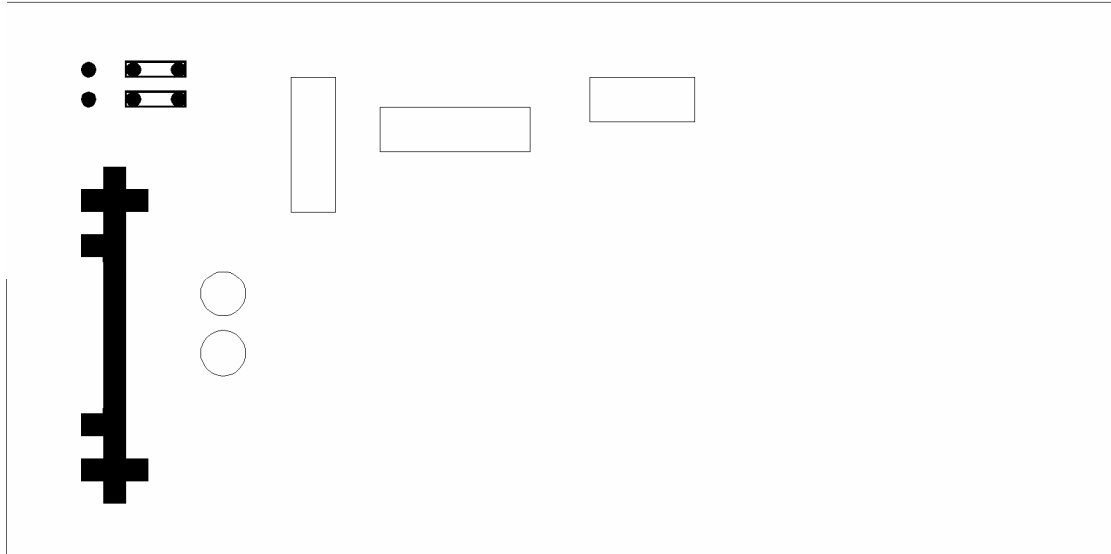

JCB Power Supply Jumper "on"

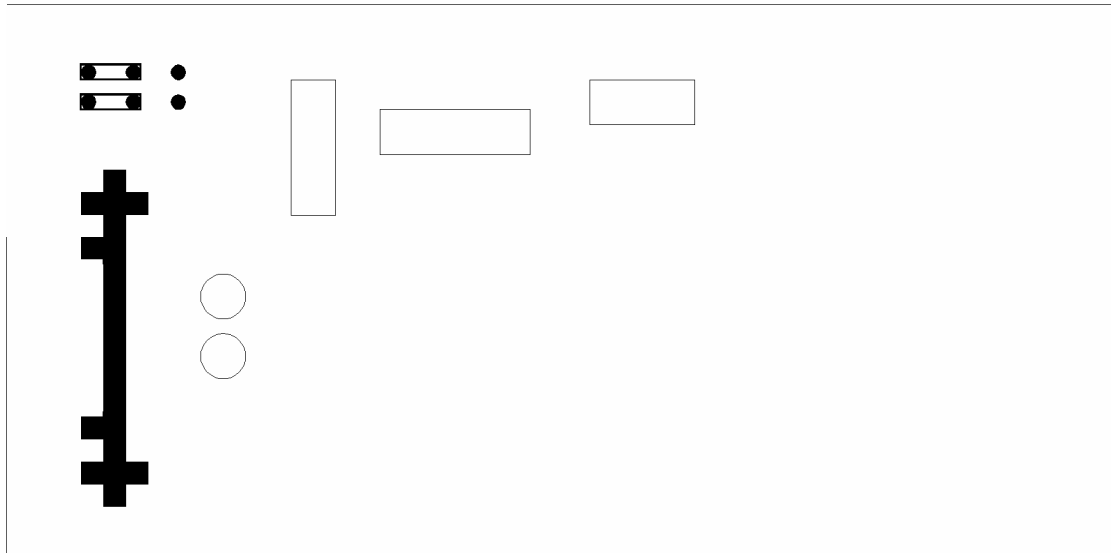

If the transmitter is fed locally (e.g. by battery with a short supply cable), the transmitter output at the Junction/Control Box remains unconnected (only for SLS20 and SLS40, no "auto background" is possible then).

In order to heat the front windows of the SLS20 transmitter and receiver, connect 12V DC or AC (200 mA) to the respective inputs at the JCB. The windows will be heated to prevent ice and dew deposits under certain weather conditions.

The window of the SLS20-A, SLS40 and SLS40-A transmitter and receiver are always heated since the heating is connected to the general supply voltage.

### **B.2.2 Source control**

The transmitter is controlled by an electronic switch in the JCB. The LED on the top of the JCB is illuminated if this switch is "on". "LED on" does not automatically mean that the source is powered on. This additionally requires an internal or external power supply and the switch being in "int" or "ext" position.

### **B.2.3 Overvoltage protection**

In order to lower the sensitivity of the system to electrical discharges in the atmosphere, the JCB contains an overvoltage protection circuit. This requires connection of the ground connector at the case with a suitable ground.

## B.2.4 Connectors

to transmitter

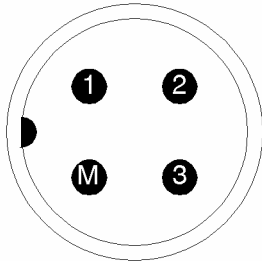

SLS20 / SLS40:

- 1: +12 V (+18 V max.)
- 2: ground (0 V)
- 3: window heating
- M: window heating

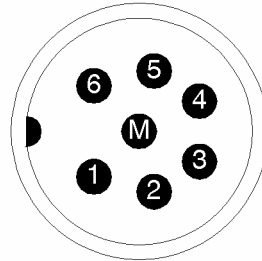

SLS20-A / SLS40-A:

- 1: +12 to +18\* V for beam steering and window heating
- 2: same as pin 1
- 3: +12 to +18\* V for laser source
- 4: beam steering signal 1
- 5: beam steering signal 2
- 6: ground (0V)
- M: same as pin 6

to receiver

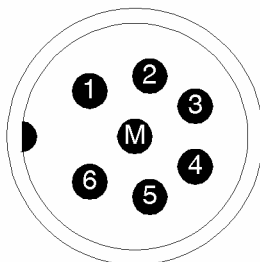

SLS20 / SLS20-A:

- 1: +12 V (+18 V max.)
- 2: - 12 V (-18 V min.)
- 3: signal channel 1
- 4: signal channel 2
- 5: window heating
- 6: window heating
- M: ground (0 V)

SLS40 / SLS40-A:

- 1: +12 to +18\*V and window heating
- 2: - 12 to -18\*V and window heating
- 3: signal channel 1A
- 4: signal channel 2A
- 5: signal channel 1B
- 6: signal channel 2B
- M: ground (0 V)

\*) actual required voltage depends on cable length, see Appendix B.2.1

(I) Connectors at the Junction/Control Box (JCB)

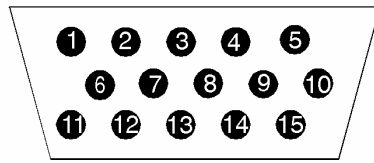

to PC/SPU

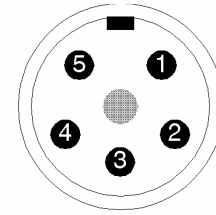

power supply

1: +12 V from PC/SPU	9: beam steering signal 2	1: +12 V, +18 V max. (SLS20)
2: - 12 V from PC/SPU	10: n/c	+12 to +18*V (all other models)
3: signal channel 1A	11: n/c	2: - 12 V, -18 V. min. (SLS20)
4: signal channel 2A	12: n/c	- 12 to -18*V (all other models)
5: source on	13: n/c	3: window heating (SLS20 only)
6: signal channel 1B	14: ground (0 V)	4: window heating (SLS20 only)
7: signal channel 2B	15: ground (0 V)	5: ground (0 V)
8: beam steering signal 1		

\*) actual required voltage depends on cable length, see Appendix B.2.1

## (II) Connectors at the Junction/Control Box (JCB)

### **Colour code of supplied power supply connection cable:**

red:	pos. supply voltage + 12-18 V	(to pin 1)
blue:	neg. supply voltage - 12-18 V	(to pin 2)
black:	ground, 0 V	(to pin 5)
yellow:	window heating (SLS20 only)	(to pin 3)
yellow:	window heating (SLS20 only)	(to pin 4)

## **B.3 Card SPC20**

### **B.3.1 General**

The card SPC20 performs the filtering and demodulation of the signal. It also contains a sample & hold circuit and the AD converter.

The SPC20 card has an additional input for 11 channels for free disposal by the user.

One output port allows the control of the source by the PC.

For operation, one card SPC20 (SLS20) or two cards (SLS40) must be plugged into the ISA bus of the PC. Alternatively, the SPC20 cards are operated with the SPU20 processing unit (Appendix B.5).

### B.3.2 Regulators and dip switches

The offset regulators P2, P4 (see below) may require re-adjustment after the SPC20 has been installed in another PC or processing unit.

Other adjustments are necessary only if parts have been replaced on the SPC20. Then follow the instructions below and always proceed in the given order:

#### a) Regulators

P5, P6: S&H offset regulation. Ground pin 3 of IC18 and IC19. Select the Alignment / Level subcommand in the SLRUN software. Measure with a digital millivoltmeter at pin 5 of IC18 and IC19. Adjust to 0.0 +/- 0.2 mV.

P1, P3: Symmetry of demodulation. Connect a 20 kHz sine voltage of 1V<sub>SS</sub> to the entrance of channels 1 and 2 and measure with an oscilloscope at pin 7 of IC7 and IC8 (test points TP9 and TP10). Adjust to achieve optimum symmetry of the half-waves.

P2, P4: Offset regulation. Connect the input channels 1 and 2 to ground. Select the Alignment / Level subcommand in the SLRUN software and adjust P2 and P4 until 10 (+/-5) digits are displayed in each channel.

#### b) Switches:

S1, S2: Amplification of first amplifier stage defining the input voltage range. The standard position is "0 1 1 1".

Switch	1	2	3	4	Input Range $V_{SS}$	Amplification
Position	0	0	0	1	0.6	10
	0	0	1	0	1.2	5
	0	0	1	1	1.8	3.33
	0	1	0	0	3.0	2
	0	1	0	1	3.6	1.67
	0	1	1	0	4.2	1.43
	0	1	1	1	4.8	1.25
	1	0	0	0	6.0	1
	1	0	0	1	6.6	0.91
	1	0	1	0	7.2	0.83
	1	0	1	1	7.8	0.77
	1	1	0	0	9.0	0.67
	1	1	0	1	9.6	0.63
	1	1	1	1	10.8	0.56

Note: Do not change the switch settings in order to increase or decrease the signal levels since the dynamic ranges of the amplifier stages are harmonized for the given positions.

S3: Base address of AD converter. The SPC20 card works standardly with base address 256. If another address is required, change the dip switch setting and the base address in the Settings / Advanced submenu.

Switch	1	2	3	4	Base Address (DEC)
Position	0	1	1	1	64
	1	0	1	1	128
	0	0	1	1	192
	1	1	0	1	256
	0	1	0	1	320
	1	0	0	1	384
	0	0	0	1	448
	1	1	1	0	512
	0	1	1	0	576
	1	0	1	0	640
	0	0	1	0	704
	1	1	0	0	768
	0	1	0	0	832
	1	0	0	0	896

c) Jumper 1 (J1): Source control mode. The jumper must be in the upper position.

Jumper 2 (J2): Base address shift. Upper position: SLS20 mode or channel A mode with SLS40 (base address shift 0). Lower position: Channel B mode with SLS40 (base address shift +8).

Jumper 3 (J3): Slowdown mode. Left position: software slowdown. Right position: Hardware slowdown. The jumper must be in the right position.

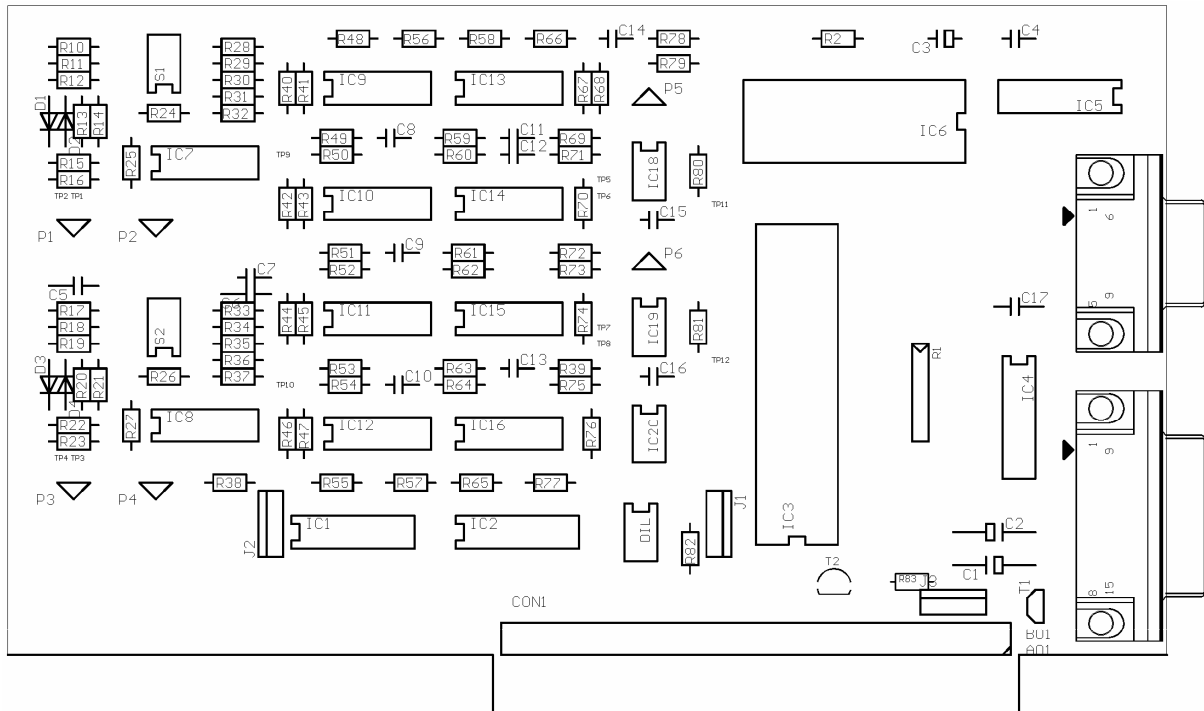

SPC20 Lay-Out

### B.3.3 Connectors

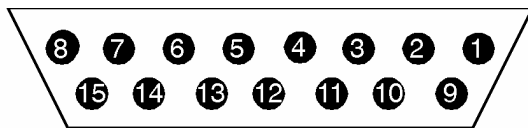

extra channels

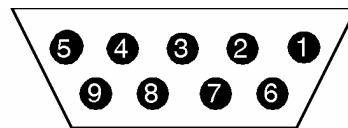

to JCB

- |                    |                      |
|--------------------|----------------------|
| 1: extra channel 1 | 9: extra channel 9   |
| 2: extra channel 2 | 10: extra channel 10 |
| 3: extra channel 3 | 11: extra channel 11 |
| 4: extra channel 4 | 12: not connected    |
| 5: extra channel 5 | 13: not connected    |
| 6: extra channel 6 | 14: not connected    |
| 7: extra channel 7 | 15: ground (0 V)     |
| 8: extra channel 8 |                      |

- |                                |
|--------------------------------|
| 1: signal channel 1            |
| 2: signal channel 2            |
| 3: pressure in (SLSDMI-1)      |
| 4: temperature 1 in (SLSDMI-1) |
| 5: temperature 2 in (SLSDMI-2) |
| 6: +12 V out                   |
| 7: -12 V out                   |
| 8: source on (5 V out)         |
| 9: ground (0 V)                |

Connectors at the SPC20

## B.4 Communication between SPC20 card and ISA bus

### B.4.1 General

If you use the SPC20 card in an ISA bus slot of a PC, you must verify that the communication between your PC and the SPC20 card works correctly. Since every PC model is individual, it is strongly recommended that you carefully read and follow the instructions in this Appendix.

### B.4.2 Base address

For the communication between the ISA bus and the SPC20 card, four addresses are needed. The base address A and the addresses A+1, A+2, and A+3. The second card of the SLS40(-A) operates with the addresses A+8, A+9, A+10, and A+11. In many cases the address range starting at DEC 256 (HEX 100) is not used by other hardware components. Then you can operate the SLS20(-A) / SLS40(-A) with the default value DEC 256. However quite often these addresses are used by other expansion cards or even internally by the PC (we found this with Compaq(R) models).

In these cases you will observe interferences of various kinds. Unfortunately, sometimes these interferences are hidden. In order to avoid erroneous measurements it is strongly recommended that you perform a laboratory check whether your selected base address is ok (see Appendix B.4.4). If you encounter communication problems, change the base address until everything works correctly.

In order to change the base address, enter the desired address number (decimal) in the Settings / Advances submenu and change the setting of dip switch S3 according to Appendix B.3.2. If the address DEC 256 does not work properly we recommend to first try the address DEC 512.

**In the SPU20 processing unit, dip switch S3 must always be set to 256.**

### B.4.3 Communication test

This procedure tests the communication between the SPC20 card and the PC.

The test can be performed in a laboratory with a 20 kHz sine wave generator or with the instruments in the field.

1. In the laboratory: Connect a 201 kHz sine wave with variable peak-to-peak voltage ( $V_{pp,max} > 12$  V) between pins 1 and 9 of the 9 pin connector of the SPC20 card (see Appendix B.3.3). Ground pin 2 by connecting it with pin 9.

In the field: Alignment the system correctly and increase the received signal by turning the channel level regulators at the Junction/Control Box and/or by bringing the receiver dip switches in a position corresponding to longer path lengths than

actually applied. The signal should finally have at least 2/3 of full scale (check with the Alignment / Level screen).

2. Run the Alignment / Histogram mode of the SLSRUN software and repeatedly scroll over the whole scale from 0 to 4095.

In the laboratory: Vary the AC input voltage from 0 V to about 12 Vp-p and repeatedly reset the histogram. The histogram for channel 1 must then show a smooth curvature without gaps, i.e. any value must be taken. The histogram in channel 2 must show only small values (near the offset which should be 5-20 digits). Then connect the AC test voltage to pin 2 at the connector and ground pin 1, reset the histogram. Now the channel 2 must show the same behaviour and channel 1 must be close to 0.

In the field: Cover the receiver window very slowly. The histogram for both channels must then show a smooth curvature without gaps, i.e. any value must be taken. Then cover beam 1 at the transmitter and reset the histogram. Now the histogram of channel 1 must show only small values (below 5% of the reading in channel 2 + 20 digits). Then cover beam 2 instead of beam 1 at the transmitter and reset the histogram. Now the values for channel 2 must be small (below 5% of the reading in channel 1 + 20 digits).

**Note that the Alignment / Histogram mode must be used for this test. The communication in the Alignment / Level mode does not correspond to the communication in the measurement mode.**

If one of the above tests fail you must assume that there is a communication problem between your PC and the SPC20 card which must be solved before you measure. Try other base addresses and increase the number of wait cycles if necessary (see Appendix B.4.4).

**Be sure not to change computer BIOS parameters or hardware components without doing another communication test afterwards.**

#### **B.4.4 Computer speed**

Another important parameter affecting the communication between the SPC20 card and the PC's ISA bus is the timing of the ISA bus. Timing problems may also be the reason for communication errors.

The SLSRUN (Version 2) software allows you to adapt the software to the ISA bus timing by introducing wait cycles. This is described in Section 3.4.6 of this manual.

## B.5 Processing unit SPU20

### B.5.1 General

The processing unit SPU20

- generates the 12V voltages needed for the SLS20 transmitter and receiver from a single (external) +12V power supply (SLS20-A, SLS40, SLS40-A only with short connection cables to transmitter and receiver, see Appendix B.2.1);
- holds one (SLS20) or two (SLS40) SPC20 cards and performs the respective analogue signal processing;
- holds the stepper motor encoder card for the SLS20-A or SLS40-A;
- accepts sensor inputs from the SLSDMI1/2 and OEBMS1 options;
- has an internal microprocessor performing the statistical calculations and sending the results to the PC via serial RS232 line (baud rate 9600). A built-in watchdog circuit generates an automatic processor reset in the case of a "hang-up".

### B.5.2 Connection and power supply

The SPU20 is connected to the Junction/Control Box (connector named "to PC") and the serial port of the PC (COM1 or COM2).

The processing unit SPU20 requires a single 12 V supply voltage with a peak current capability of 2 A (see below).

**After power has been connected, the SPU20 needs approx. 60 seconds to boot up.** Note that in the case of a watchdog reset, there will also be this 60 seconds delay.

The supply voltage must be connected to the connector "to power supply" as shown on the following page.

The supplied cable is colour coded as follows:

red cable: supply voltage +12 V (max 13.8 V, 2 A peak)  
black cable: supply voltage ground

With the SLS20, the voltage for the window heating of transmitter and receiver (prevention of ice and dew deposits) must be connected to the JCB (see Appendix B.2.1). This can be the same voltage as used for the SPU20.

There is a connector for the input of the extra channels, 0 to 10 V (see next page).

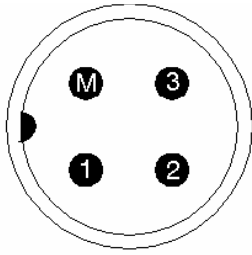

pressure  
(SLSDMI-1 only)

- 1: +12 V
- 2: ground (0 V)
- 3: pressure in
- M: signal ground

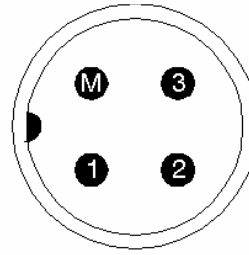

temperature / temperature difference  
(SLSDMI-1 / SLSDMI-2 only)

- 1: +12 V
- 2: ground (0 V)
- 3: temperature 1 in
- M: temperature 2 in

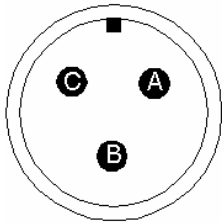

to power supply

- A: +12 V
- B: case / shield
- C: ground (0 V)

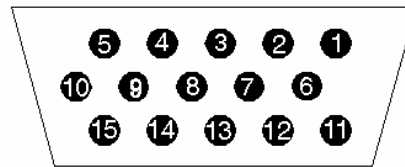

to JCB

- 1: +12 V
- 2: - 12 V
- 3: signal channel 1A
- 4: signal channel 2A
- 5: source on
- 6: signal channel 1B
- 7: signal channel 2B
- 8: beam steering signal 1
- 9: beam steering signal 2
- 10: pressure in (SLSDMI-1)
- 11: temperature 1 in (SLSDMI-1)
- 12: temperature 2 in (SLSDMI-2)
- 13: n/c
- 14: ground (0 V)
- 15: ground (0 V)

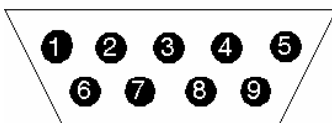

RS 232 serial port

- 1: not connected
- 2: receive data
- 3: transmit data
- 4: not connected
- 5: ground
- 6, 7, 8, 9: not connected

use "null modem" cable  
for connection with PC

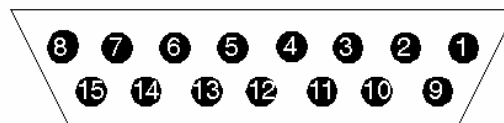

extra channels

- 1: extra channel 1
- 2: extra channel 2
- 3: extra channel 3
- 4: extra channel 4
- 5: extra channel 5
- 6: extra channel 6
- 7: extra channel 7
- 8: extra channel 8
- 9: extra channel 9
- 10: extra channel 10
- 11: extra channel 11
- 12: not connected
- 13: not connected
- 14: not connected
- 15: ground (0 V)

Connectors at the SPU20 processing unit

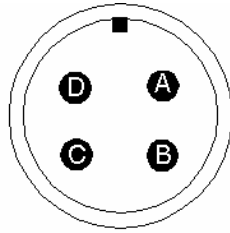

to CONSH1 (multiplex)

- A: +12 V
- B: ground (0 V)
- C: receive data, connect to 'transmit data' at CONSH1  
(data stream from CONSH1 to SPU-OEBMS1)
- D: transmit data, connect to 'receive data' at CONSH1  
(data stream from SPU-OEBMS1 to CONSH1)

Connector for CONSH1 at the SPU-OEBMS1

## Appendix C Specifications

### General:

source:	laser diode
wavelength:	670 nm±10 nm
lifetime:	20 000 hours typically
beam collimation:	by 3 lenses
beam divergence:	10 mrad x 3.5 mrad
scan cone radius:	1° (SLS20-A and SLS40-A only)
beam output power:	1 mW mean, 2 mW peak
modulation frequency:	20 kHz
modulation depth:	90%
beam displacement:	2.7 mm
number of detectors:	2 (SLS20 and SLS20-A) 4 (SLS40 and SLS40-A)
detector separation:	2.7 mm
detector diameter:	2.5 mm
receiver bandwidth:	4 kHz

### Supply Voltages and Currents:

transmitter SLS20	+12 V 0.05 A
window heating	12 V 0.1 A
transmitter SLS40	+12 V 0.15 A (including window heating)
transmitter SLS20-A / SLS40-A	+12 V 0.35 A (including window heating)
receiver SLS20	+12 V 0.05 A -12 V 0.05 A
window heating	12 V 0.1 A
receiver SLS20-A	+12 V 0.15 A -12 V 0.15 A (including window heating)
receiver SLS40 / SLS40-A	+12 V 0.2 A -12 V 0.2 A (including window heating)

A larger voltage must be supplied at the remote cable end to allow for voltage drop over the cable (see table in Appendix B.2.1).

SPC20 card	+12 V 0.1 A -12 V 0.1 A
(via ISA bus)	+ 5 V 0.2 A

SPU20 processing unit	+12 V 0.7 A for SLS20(-A), peak 1.5 A +12 V 1.4 A for SLS40(-A), peak 2.0 A
-----------------------	--

### **Temperature Ranges:**

Transmitter	-20°C to 50°C operation -40°C to 60°C storage
Receiver	-25°C to 60°C operation -40°C to 60°C storage
JCB	-25°C to 50°C operation -40°C to 60°C storage
SPC20	0°C to 50°C operation -40°C to 60°C storage
SPU20	-20°C to 40°C operation -40°C to 60°C storage

### **Dimensions and Weights:**

SLS20/SLS40 transmitter	0.65 m x 0.11 m x 0.11 m, 3.0 kg
SLS20-A/SLS40-A transmitter	0.70 m x 0.11 m x 0.11 m, 3.5 kg
SLS20/SLS20-A receiver	0.60 m x 0.11 m x 0.11 m, 2.9 kg
SLS40/SLS40-A receiver	0.62 m x 0.12 m x 0.12 m, 4.1 kg
JCB SLS20	0.14 m x 0.12 m x 0.06 m, 0.4 kg
JCB SLS40	0.22 m x 0.19 m x 0.10 m, 1.8 kg
SPC20	0.19 m x 0.11 m x 0.02 m, 0.2 kg
SPU20	0.25 m x 0.22 m x 0.19 m, 5.5 kg

## Appendix D Avoiding measurement errors

### D.1 Stability of the mounting platforms

Wind induced mechanical vibrations of the instruments, in particular of the SLS20(-A) transmitter, may seriously affect the measurements. Since this error cannot be corrected for later, always verify that the transmitter and the receiver are stably mounted.

Instabilities of the mountings affect the measurement as follows: A vibration (mainly a twist) of the transmitter causes a wander of the laser beams at the receiver and hence produces a variation of the measured intensities. This intensity variation is added to the turbulent intensity fluctuations. The calculated values of  $C_n^2$  will be too high, the calculated  $l_0$  will be too low or too high. This causes errors in the heat and (even more pronounced) in the momentum flux. Note that stability problems generally are more important when the turbulent intensity fluctuations (or  $C_n^2$ ) are small.

The SLS40(-A) receiver has a separate pair of detectors which allows automatic identification of and correction for the transmitter vibrations by the SLSRUN software. However also the SLS40(-A) transmitter should be mounted as stable as possible.

In principle, a vibration of the receiver may have a similar effect. However, since the field of view of the receiver is much larger than the beam's divergence, the stability of the receiver mounting is much less critical.

As a rule of thumb, the SLS20(-A) is affected by vibrations having such a magnitude that you can feel them with your hands at the transmitter. If you cannot improve the mounting (e.g. if you use tripods), apply a wind shield mounted upwinds to the transmitter tripod.

In order to test the stability of the mountings, you may also try to move and twist the instruments with your hands. Estimate the wind force acting: This force must not move the instruments. Take into account that already a fraction of 1 mrad (0.05 degrees) twist of the transmitter has an effect.

### D.2 Low signal - to - noise ratio

The SLSRUN software displays an error message if the signal-to-noise ratio is unacceptable. Marginal cases pass the software test and may cause errors of a limited extend.

A low signal-to-noise ratio means that a significant amount of noise is added to the turbulent signal fluctuations. This noise is uncorrelated in both channels. Hence it tends to increase the calculated  $C_n^2$  and decrease the calculated  $l_0$  values.

Accordingly the calculated heat and momentum fluxes will be too high.

Signal-to-noise problems only occur when  $C_n^2$  is very small, i.e. near the measurement limit. They rapidly become negligible as  $C_n^2$  increases. Since small  $C_n^2$  values go along with small heat fluxes, possibly affected periods in heat flux time series are easily identified. The affected periods typically last several minutes until the heat flux (absolute value) has increased.

With the SLS20(-A)/ SLS40(-A), signal-to-noise limitations are rare. If observed, they are mainly due to transmitter vibrations (see above). They may also have some importance under special measurement conditions, e.g. if measurements are taken over water or under weather conditions which are connected with small heat fluxes (absolute values).

You improve the signal-to-noise ratio by

- a. shortening the path if it is longer than 200 m or lengthening the path if it is shorter than 100 m
- b.
- c. lowering the measurement height if the surface roughness and your measurement task allows.

### D.3 Inner scale measurement range

There is a lower limit of the  $\ell_0$  values which can be accurately determined by the SLS20(-A) / SLS40(-A). If  $\ell_0$  falls below this limit, the instrument is susceptible to measurement errors.

The lower  $\ell_0$  limit depends on the path length. It is 2 mm for paths of 100 m or longer, 2.5 mm for a path of 80 m, and 3.5 mm for a path of 50 m. If small  $\ell_0$  values are to be measured, it is therefore advisable to use a minimum path length of 100 m.

Note that  $\ell_0$  becomes smaller at larger wind speeds or closer to the ground. The height dependence of  $\ell_0$  may allow you to adapt the height of the path to the given measurement range.

### D.4 Crosstalk

The SLRUN software corrects for crosstalk between the two channels. This correction can be essential.

The Measure Background procedure for the determination of the crosstalk coefficients should always be performed after the instruments have been newly

installed (see section 2.3 g).

Incorrect crosstalk coefficients will systematically

- either            a) increase  $C_n^2$ ,  $\ell_0$ ,  
                         slightly change heat flux,  
                         decrease (absolute value of) momentum flux
- or                 b) vice versa,

depending on the crosstalk coefficients erroneously used. If crosstalk coefficients of 0.0 are used or the "ignore background" option is selected, the error direction is as described under a).

## D.5 Misalignment

Misalignment of the transmitter (i.e. the receiver being at the edge of the laser beam) has only a minor effect on the accuracy of the measurements as long as the received intensities are sufficiently high. The main disadvantage of a transmitter misalignment is that it magnifies the influence of transmitter instabilities (see section 1, Appendix D). Also, of course, the signal-to-noise ratio becomes worse.

The alignment of the receiver is easier than that of the transmitter due to the larger field of view. However the correct receiver alignment is very essential to achieve correct measurement results. Special care must be taken to insure that the transmitter is within the field of view of both detectors.

## D.6 Different intensities in the two channels

There is no error caused by a difference of the mean intensities in the two channels (SLS20(-A)) or four channels (SLS40(-A)).

## Appendix E Error and warning codes

### erX and erY:

An error-free and warning-free measurement is coded by "0".

A background calibration measurement is coded by "4".

Codes less than 4 are warning codes. Diagnosis data with such error levels are still used for the calculation of the main data period's output quantities.

Codes larger than 4 are error codes. Diagnosis data with such error levels are rejected and not further used.

Simultaneously occurring error and warning codes sum up. Example: the code 729 consists of the codes 1, 8, 16, 64, 128 and 512.

### The meaning of the codes is:

0: No error or warning.

1: Strong fluctuations caused the signal to regularly exceed the AD range. A noticeable correction has been applied. If this warning code repeatedly occurs, it may be advisable to reduce the signal level (level adjustment at JCB or amplifier dip switch setting) or to use a shorter or higher propagation path.

2: Saturation of the fluctuations was observed (limit of weak scattering theory, see Appendix A). If this warning code regularly occurs you must use a shorter or higher propagation path.

4: Background measurement. (No accumulation with other codes.)

8: Correlation was unrealistically low. This happens in the case of precipitation, when the inner scale falls below the measurement range (strong wind) or with transmitter vibration especially under small  $C_n^2$  conditions.

16: Correlation was unrealistically high. This happens in the case of a temporary obscurations of the total beam, when there are severe pointing instabilities of the transmitter or receiver or when the laser beam has shortly been switched on (e.g. auto background) under small  $C_n^2$  conditions.

32: Histogram-Test 1. The observed intensity distribution cannot be caused by turbulence only. Crossing of insects or particles is likely.

64: Histogram-Test 2. The observed intensity distribution cannot be caused by turbulence only. Crossing of insects or particles is likely.

128: Poor signal-to-noise ratio. Extremely small thermal turbulence. Occurs when fluxes are small (sunset, sunrise, large and dense cloud cover) and in the case of laminar flow (calm nights). Lower measurement heights improve the signal-to-noise ratio.

256: A drift in the average received intensity was encountered. Possible reasons are an insufficient pointing stability of the transmitter or receiver, variations in the path transmission due to fog etc., or a drift in the source output power (low battery voltage or automatic background mode under small  $C_n^2$  conditions). Note that the tolerable limit depends on the strength of the intensity fluctuations.

512: The variances in the two channels differ significantly. Crossing of insects or particles is likely. Another possible reason is a misalignment of the instruments or a vibration of the transmitter.

1024: The received average intensity has dropped to a value which is very much lower than that at the beginning of the measurement. If there is no fog or obscuration, check alignment, transparency of windows, transmitter power and pinhole adjustment.

#### **erW:**

0: No error or warning

1: The crosswind measurement range has been approached or exceeded.

2: The crosswind algorithm failed.

4: The SLS40(-A) transmitter vibration was too large.

If erW contains 2 or erX or erY are 4 or larger, the diagnosis data periods are not used for the calculation of the crosswind.

#### **erO:**

0: No error or warning

1: During the last averaging period, a procedure to determine the heat conductivity of the ground has been performed. This procedure can induce a small error in the soil heat flux measured during the same period. The error typically has an order of about 1 W/m<sup>2</sup>.

2: A sensor interface reported data overflow.

4: An error was observed in the communication between the SPU signal processing unit and the PC.

8: An error was observed in the communication between the sensor interfaces and the SPU signal processing unit.

## Appendix F Calibration of extra channel data

The extra channel input of the SPC20 card or SPU20 processing unit can read up to 11 voltages between 0 and 10 V which are displayed and stored by SLSRUN.

The extra channel calibration is contained in a file named "slsxchan.dat". This file can be edited to change the calibration.

The file contains 11 lines, each consisting of

1. the consecutive number of the extra channel
2. the offset corresponding to 0 V input
3. the slope in increment per 1 V input change

separated by commas.

**Example:** If the file "slsxchan.dat" contains

```
1,-5000,1000
2,0,409.5
3,0,409.5
4,0,409.5
5,0,409.5
6,0,409.5
7,0,409.5
8,0,409.5
9,0,409.5
10,0,409.5
11,0,409.5
```

this means that extra channel 1 displays -5,000 to +5,000 and extra channels 2 to 11 display 0 to 4,095 (corresponding to the 12 bit resolution of the AD converter) for an input voltage range of 0 to 10 V.

## Appendix G Interfacing and calibration of OEBMS1 sensors

All OEBMS1 sensors (pyrradiometer, pyranometer, 3 soil heat flux sensors) have a thermopile mV output. These outputs are analog-to-digital converted in individual CONSH1 interface units.

The mV input ranges of the CONSH1 interface units are adapted to the respective sensors connected.

The CONSH1 numbers are related to the following sensors:

- CONSH1 #1: Pyrradiometer, upper surface
- CONSH1 #2: Pyrradiometer, lower surface
- CONSH1 #3: Pyranometer
- CONSH1 #4: Soil heat flux sensor SH1 #1
- CONSH1 #5: Soil heat flux sensor SH1 #2
- CONSH1 #6: Soil heat flux sensor SH1 #3

Connection scheme:

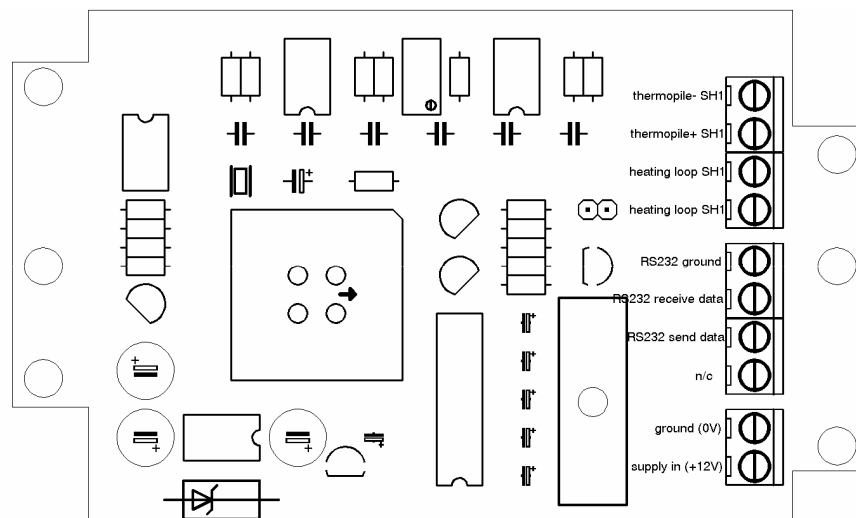

The calibration data for the OEBMS1 sensors are contained in the file "slsconsh.dat" which is provided with the OEBMS1 sensors on delivery and not contained in the SLSRUN standard software package. **Therefore backup and carefully keep this file.** At any upgrade of the software, you will need it.

You may edit and change the file "slsconsh.dat" for recalibration.

The file "slsconsh.dat" contains 6 lines. Each line consists of

1. the consecutive number of the CONSH1 unit
2. the sensitivity of the respective CONSH1 unit in  $\mu\text{V}/\text{digit}$
3. the respective sensor calibration in  $\mu\text{V}/(\text{W}/\text{m}^2)$

separated by commas.

**Example:** If the file "slsconsh.dat" contains

```
1,12.65,26.500
2,12.65,26.500
3,3.80,9.650
4,3.71,64.5
5,3.68,65.1
6,3.77,65.0
```

this means that CONSH1 #1 and #2 have an input sensitivity of 12.65  $\mu\text{V}/\text{digit}$  and CONSH1 #3 has an input sensitivity of 3.80  $\mu\text{V}/\text{digit}$ . The pyrradiometer calibration is 26.500  $\mu\text{V}/(\text{W}/\text{m}^2)$  for the upper surface and also 26.500  $\mu\text{V}/(\text{W}/\text{m}^2)$  for the lower surface. The input sensitivities of CONSH1 #4, #5 and #6 are 3.71  $\mu\text{V}/\text{digit}$ , 3.68  $\mu\text{V}/\text{digit}$  and 3.77  $\mu\text{V}/\text{digit}$ . The calibration factors of the soil heat flux sensors are 64.5  $\mu\text{V}/(\text{W}/\text{m}^2)$ , 65.1  $\mu\text{V}/(\text{W}/\text{m}^2)$  and 65.0  $\mu\text{V}/(\text{W}/\text{m}^2)$ .

## Appendix H Interfacing and calibration of SLSDMI sensors

The Temperature Sensor Interface SLSDMI-1 / SLSDMI-2 converts the resistance of two Pt1000 Platinum temperature sensors into two output voltages 0 to 10 V corresponding to a temperature range of -50 to +50°C.

### Connection scheme:

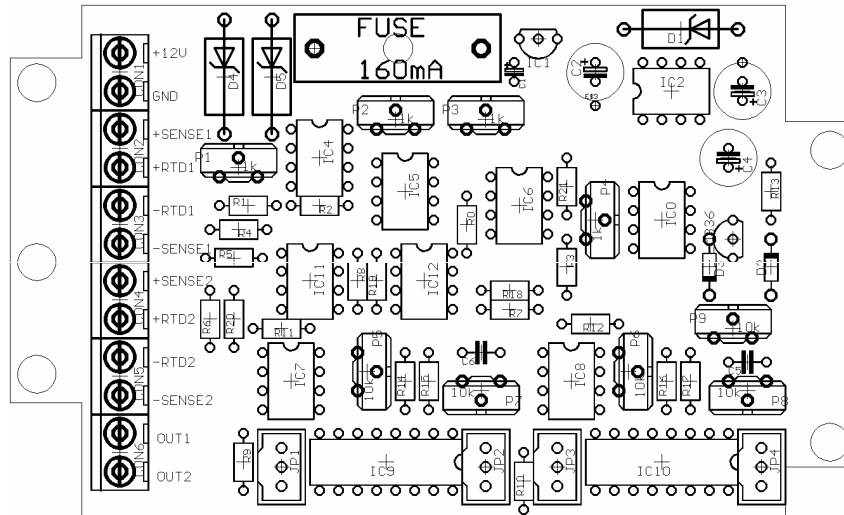

V+	+12 to +15 V supply voltage
GND	supply and output ground
+SENSE1	voltage out sensor 1, positive
+RTD1	current sensor 1, positive
-RTD1	current sensor 1, negative
-SENSE1	voltage out sensor 1, negative
+SENSE2	voltage out sensor 2, positive
+RTD2	current sensor 2, positive
-RTD2	current sensor 2, negative
-SENSE2	voltage out sensor 2, negative
OUT1	output voltage or current sensor 1
OUT2	output voltage or current sensor 2

### Jumper positions:

Jumpers 1-4	upper position: voltage output
	lower position: current output

(The 4-20 mA current output is optionally available for lines of more than 300 m length.)

The calibration data for the temperature and pressure sensors are contained in the file SLSDMI.DAT. This file is structured as:

PP, DP  
TT1, DT1  
TT2, DT2

where

- PP is the resulting pressure (hPa) at 0 V input voltage
- DP is the increase of the pressure (hPa) per 1 V increase of the input voltage
- TT1 is the resulting temperature 1 (°C) at 0 V input voltage
- DT1 is the increase of the temperature 1 (°C) per 1 V increase of input voltage
- TT2 is the resulting temperature 2 (°C) at 0 V input voltage
- DT1 is the increase of the temperature 2 (°C) per 1 V increase of input voltage

Depending on the type of temperature and pressure sensor, the file SLSDMI.DAT has different content. For instance, without adjustments, the file SLSDMI.DAT may contain the following data:

800, 60 corresponding to a range 800 to 1100 hPa  
-50, 10 corresponding to a range -50 to +50 °C  
-50, 10 corresponding to a range -50 to +50 °C

A further example are the following data:

600, 100 corresponding to a range 600 to 1100 hPa  
-50, 10 corresponding to a range -50 to +50 °C  
-50, 10 corresponding to a range -50 to +50 °C

By editing the file SLSDMI.DAT, the output can be adjusted to

1. correct for the voltage offset over the ground line
2. further increase the accuracies of the Pt1000 sensors and the interface circuits, in particular equilibrating the two sensors

## Appendix I CE Declaration of Conformity



### Declaration of Conformity according to EN 45014

Name and address of manufacturer:

Scintec AG  
Wilhelm-Maybach-Str. 14  
72108 Rottenburg  
Germany

We declare that the products

**Surface Layer Scintillometer**

**Models SLS20, SLS20-A, SLS40, SLS40-A**

comply with the Electromagnetic Compatibility Regulations (EMC) and, as far as applicable, the Low Voltage Directive (LVD) of the European Community.

Conformity is guaranteed for delivered complete systems and independently operable components. This declaration does not refer to systems resulting from an integration of external components such as data loggers, PCs, power supplies, cable, etc. by others than the manufacturer.

Applicable norms and standards:

EN 50081-1, EN 50082-1  
EN 55022 Class B  
EN 60555-2, EN 60555-3  
EN 55014  
IEC 801-1 (1988), IEC 801-2 (1991), IEC 801-3 (1984)  
CCITT K20, IEC 65 (Sec) 144