

MetPak II

Weather Station



User Manual

Doc No. 1723-PS-0001
Issue 6

Applies to MetPak II's:-
Serial Number 345 and higher.
Firmware 2436 V2.00 and higher.



Gill Instruments Limited
Saltmarsh Park,
67 Gosport Street,
Lymington,
Hampshire.
SO41 9EG
UK

Tel: +44 (0) 1590 613500
Fax: +44 (0) 1590 613501
E-mail: anem@gill.co.uk
Website: www.gill.co.uk



Foreword

© 2010 Gill Instruments Ltd. All rights reserved.

Thank you for purchasing the MetPak II manufactured by Gill Instruments Ltd. To achieve optimum performance we recommend that you read the whole of this manual before proceeding with use.

Gill products are in continuous development and therefore specifications may be subject to change and design improvements without prior notice.

The information contained in this manual remains the property of Gill Instruments and should not be copied or reproduced for commercial gain.

Guarantee

For terms of guarantee, please contact your supplier.

Warranty is void if the coloured Wind Sensor security seal is damaged or broken, or the Wind Sensor transducer caps have been damaged.

Trademarks

Microsoft and Windows are registered trademarks of Microsoft Corporation.

All other brands and product names are trademarks or registered trademarks of their respective owners.

Cautions and Notes

The following symbols are used in this guide:



CAUTION. This indicates an important operating instruction that should be followed to avoid any potential damage to hardware or property, loss of data, or personal injury.



NOTE. This indicates important information to help you make the best use of this product.

Contents

1.	Introduction	1
1.1	Principle of Operation.....	2
1.1.1	Wind Speed and Direction Sensor.....	2
1.1.2	Radiation Shield	3
1.1.3	Temperature and Relative Humidity Sensor with Dewpoint Output.....	3
1.1.4	Barometric Pressure.....	3
1.2	Abbreviations	4
1.3	Quick Start Guide.....	5
2.	Installation	7
2.1	Pre-Installation Checks	7
2.2	Installation.....	8
2.2.1	Bench system test	8
2.2.2	Equipment Required.....	8
2.2.3	Cabling.....	8
2.2.4	Communication connections.....	10
2.2.5	Mounting MetPak II	14
3.	Operation	17
3.1	MetView.....	17
3.1.1	Opening MetView	17
3.1.2	Scanning for Devices.....	18
3.1.3	The MetView Console	19
3.1.4	Console Display Options	20
3.1.5	Define Configuration Settings.....	21
3.1.6	Data logging	22
3.2	Configuring MetPak II.....	25
3.2.1	Configuring MetPak II using MetSet	26
3.2.2	MetSet Editing Screen.....	28
3.2.3	Configuring MetPak II using HyperTerminal	30
3.2.4	Configuring MetPak II for NMEA Output.	34
3.2.5	Configuring MetPak II for SDI-12.....	35
3.2.6	SDI-12 Commands.....	35
3.2.7	Safe Mode.....	37
4.	Troubleshooting.....	39
4.1	Fault-Finding	39

Contents

4.2	Servicing.....	40
4.3	Bench Tests.....	40
5.	Maintenance	41
6.	Technical Information.....	i
6.1	Specification	i
6.2	MetPak II Hub PCB Connections	iii

Figures

Figure 1	MetPak II	1
Figure 2	Compass points	2
Figure 3	Position of Temperature and Relative Humidity Probe in the Radiation Shield	3
Figure 4	Internal view of the hub box	10
Figure 5	Connection of Gill USB Cable (Part No. 1723-10-051)	11
Figure 6	RS232 connections	11
Figure 7	RS422 connections	12
Figure 8	RS485 Connections	12
Figure 9	SDI-12 connections	13
Figure 10	Correct mounting position for MetPak II	15
Figure 11	Opening MetView Screen	17
Figure 12	Scanning for MetPak II Devices	18
Figure 13	The MetView Console	19
Figure 14	The Configure Sensor screen	21
Figure 15	Reporting Format	21
Figure 16	Setting up data logging	22
Figure 17	A typical data log (viewed in Windows Notepad)	24
Figure 18	Opening MetSet Screen	26
Figure 19	Summary of MetPak II Device Settings using MetSet	27

Tables

Table 1	Abbreviations	4
Table 2	Recommended Belden cable types	9
Table 3	Maximum cable lengths for supported communication networks	9
Table 4	Connection status indicators	19
Table 5	MetView scale and unit options	20
Table 6	MetView averaging options	20
Table 7	Max/min markers	20
Table 8	Default configuration settings	25
Table 9	MetPak II configuration commands	31
Table 10	Abbreviations used in UNIT configuration command	33
Table 11	Common problems and their solution	39
Table 12	Status codes as output with the MetPak II data string	40
Table 13	HygroClip connections (6-way connector J1)	iii
Table 14	WindSonic anemometer connections (8-way connector J4)	iii
Table 15	PC communications (8-way connector, J5)	iii



1. Introduction

MetPak II is a compact and lightweight multi-sensor instrument that measures the most essential weather parameters. Gill ultrasonic technology, as used in the proven WindSonic instrument, measures wind speed and direction. Temperature and Humidity are measured and Dewpoint calculated using an industry standard probe housed in a naturally aspirated radiation shield. Barometric pressure is measured using an industry standard sensor.

The instrument is supplied with digital ASCII RS232/RS422/485 (2 wire point to point) and digital SDI-12 outputs. NMEA 0183 output is also configurable. An electrical hub box is fitted to the mounting bracket allowing convenient termination of all electrical cables.

The instrument uses a rugged U-bolt mounting clamp that attaches to any vertical pipe up to 50mm (2") diameter.

An electrical hub box is fitted to the mounting bracket for termination of data and power cables.

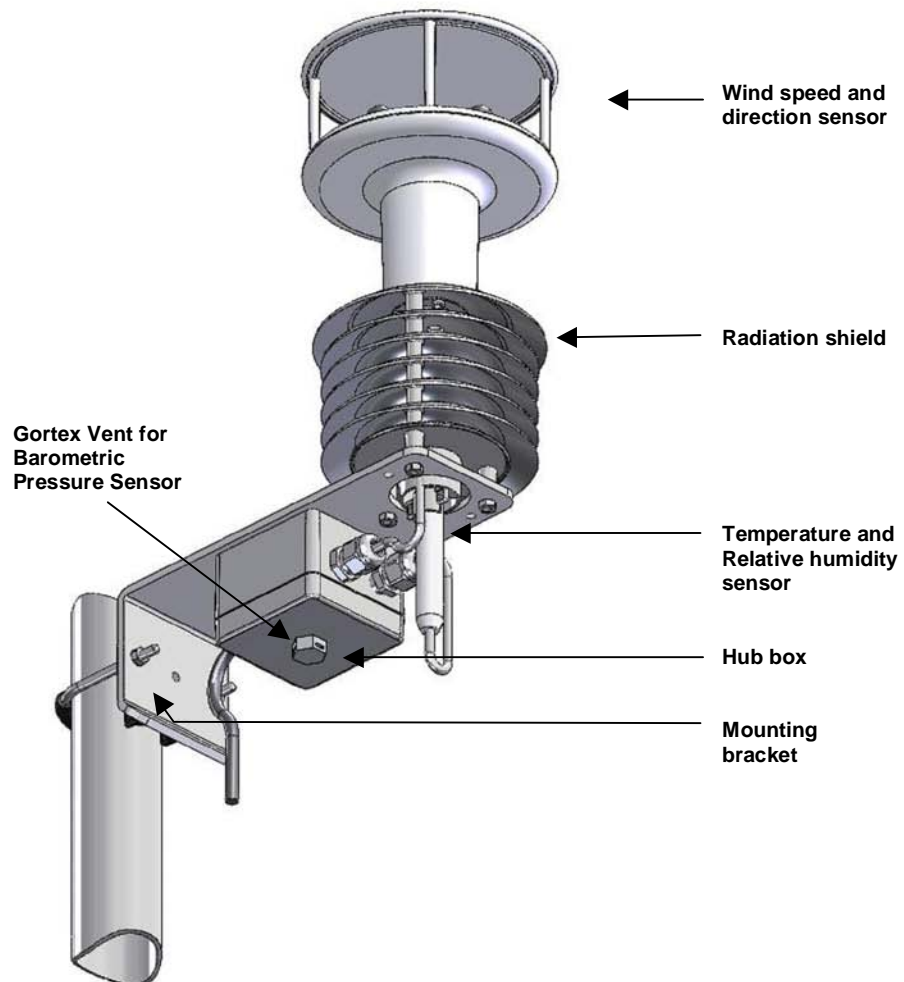

Figure 1 MetPak II

1.1 Principle of Operation

1.1.1 Wind Speed and Direction Sensor

The MetPak II uses the WindSonic wind speed and direction sensor. The WindSonic measures the times taken for an ultrasonic pulse of sound to travel from the North transducer to the South transducer, and compares it with the time for a pulse to travel from S to N transducer. Likewise times are compared between West and East, and E and W transducer.

If, for example, a North wind is blowing, then the time taken for the pulse to travel from N to S will be faster than from S to N, whereas the W to E, and E to W times will be the same. The wind speed and direction can then be calculated from the differences in the times of flight on each axis. This calculation is independent of factors such as temperature.

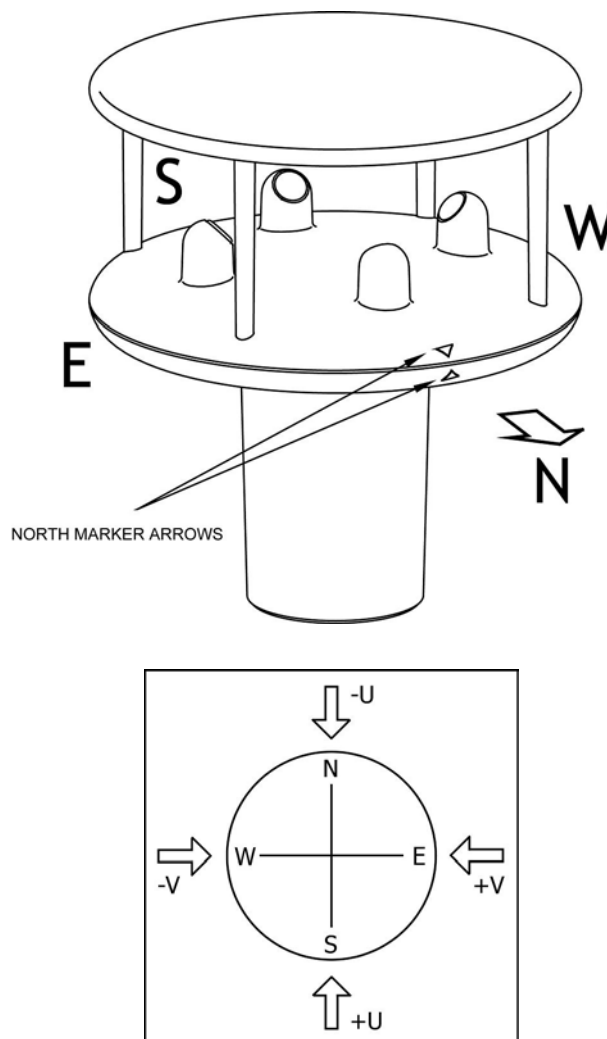

Figure 2 Compass points

Figure 2 shows the compass point and polarity of U and V if the wind components along the U and V axis are blowing in the direction of the respective arrows.

1.1.2 Radiation Shield

The Multi-Plate Radiation Shield protects temperature and relative humidity sensors from error-producing solar radiation and precipitation. This shield relies on a combination of plate geometry, material and natural ventilation to provide effective shielding.

1.1.3 Temperature and Relative Humidity Sensor with Dewpoint Output

The Rotronic HygroClip module is a complete instrument, with integrated temperature compensation. Calibration data is maintained within the integrated electronics. It provides digital output signals for Relative Humidity, Temperature and Dewpoint to the MetPak II Hub box.

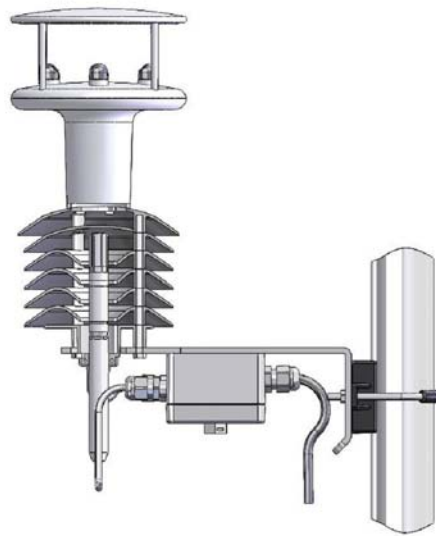

Figure 3 Position of Temperature and Relative Humidity Probe in the Radiation Shield

1.1.4 Barometric Pressure

Barometric pressure output is provided by a solid-state device fitted on to the circuit board in the MetPak II hub box. Vent to atmosphere is via a Gortex filter, which protects the pressure sensor from the effects of wind and rain.

1.2 Abbreviations

Table 1 Abbreviations

Item	Meaning
ASCII	American Standard Code for Information Interchange
C	Centigrade
CAL	Calibration
CD	Compact Disc
COM	Communications
CR	Carriage Return
CSV	Comma Separated Variable
ETX	End of String
F	Fahrenheit
FPM	Feet per Minute
HF	High Frequency
HPA	Hecto-Pascals
HTML	Hyper Text Markup Language
Hz	Hertz
IMM	International Maritime Mobile
In Hg	Inches of Mercury
K	Kelvin
KPH	Kilometres per Hour
KTS	Knots
LF	Line Feed
M Bar	Milli Bars
Max	Maximum
MF	Medium Frequency
Min	Minimum
Mm Hg	Millimetres of Mercury
MPH	Miles per Hour
MS	Microsoft
MS	Metres per Second
NMEA	National Marine Electronics Association
NSEW	North South East West
NVM	Non-Volatile Memory
PC	IBM compatible Personal Computer
ROM	Read Only Memory
RS232	Communications standard
RS422	Communications standard
Rx	Receive
RXD	Received Data
SDI-12	Serial – Data Interface standard for microprocessor based sensors
STX	Start of String
Tx	Transmit
TXD	Transmitted Data
VHF	Very High Frequency
WIMWV	Wind Instrument Mean Wind direction and Velocity
WIXDR	Wind Instrument Cross track error Dead Reckoning
WMO	World Meteorological Organisation

1.3 Quick Start Guide

This section provides an overview of the installation and operation of MetPak II. For more detailed information about any of the steps, use the references to other sections of this manual.

1. Decide how you are going to connect MetPak II to your PC or communications network. MetPak II supports the following options:
 - USB connection using Gill's RS232 to USB 1.8M configuration cable (includes integral 5V power supply). To order, contact your dealer quoting part number: 1723-10-051).

NOTE. You could use an equivalent RS232-USB adapter such as EasySynch RS232 to USB adaptor.

- RS232 connection using standard cable and PC COM port. Separate 5V to 30V dc power supply also required.
- RS422 using RS232 converter.
- RS485 2 wire point-to-point communication using suitable converter.
- SDI-12 connection (note SDI-12 is not compatible with MetView Software).

NOTE. MetPak II is pre-configured for RS232 communication (factory setting). If you want to use an alternative communication protocol, you will need to set up the unit using an RS232 connection (with an appropriately wired cable), change the setting (see page 25), shut the unit down, attach a cable for the new communication type, and then restart the unit.

2. Unpack MetPak II. Check that you have the following:
 - MetPak II unit (Part No.1723-PK-100).
 - Gill MetView, MetSet Software and Manual supplied on the CD.

If any parts are missing, please contact your dealer.
3. Open the hub box by unfastening the four retaining screws. Locate the connector: J5 (see Page 10, Figure 4). Carefully pull the connector block from its pins.
4. Prepare the communications cable by stripping the wires to a length of 8mm. Feed the prepared cable through one of the two available ports on the side of the hub box.
5. Connect the cable to J5 as described on page 10 for your chosen communications method.
6. Carefully press J5 onto its circuit board pins.
7. Replace the top on the connection box. Tighten the gland on the connection port to seal the cable in place.
8. If you are carrying out a bench test, continue to step 13. When you have finished testing, return to Step 9.
9. Unfasten the mounting bracket. Position the MetPak II against the mounting post (see page 15), replace the mounting bracket and tighten sufficiently to hold the unit in place but allowing it to be rotated or moved up and down the pole.

10. Check the orientation and alignment of the unit (see page 14).
11. Check the height of the unit and ensure it is clear of any obstructions, including the mounting post, that could interfere with MetPak II's measurements (see page 14).
12. Tighten the mounting bracket to hold the unit firmly in place.
13. Connect the communications cable to your PC or network device.
14. Place the MetPak II CD in your PC's CD drive and install MetView.
15. Run MetView.
16. Select the **Connect to the first device found** check box. Click on the **Scan** button. MetView Software searches for the MetPak II connection.



17. Allow the software to search for the MetPak II unit through the available COM ports. If you have more than one unit configured, you may have to select the unit based on the COM port assignments.
18. MetView reads the unit and reports its wind, temperature, humidity, dewpoint and pressure measurements (see below). If you have any problems, please read the Installation chapter for full details of these steps.

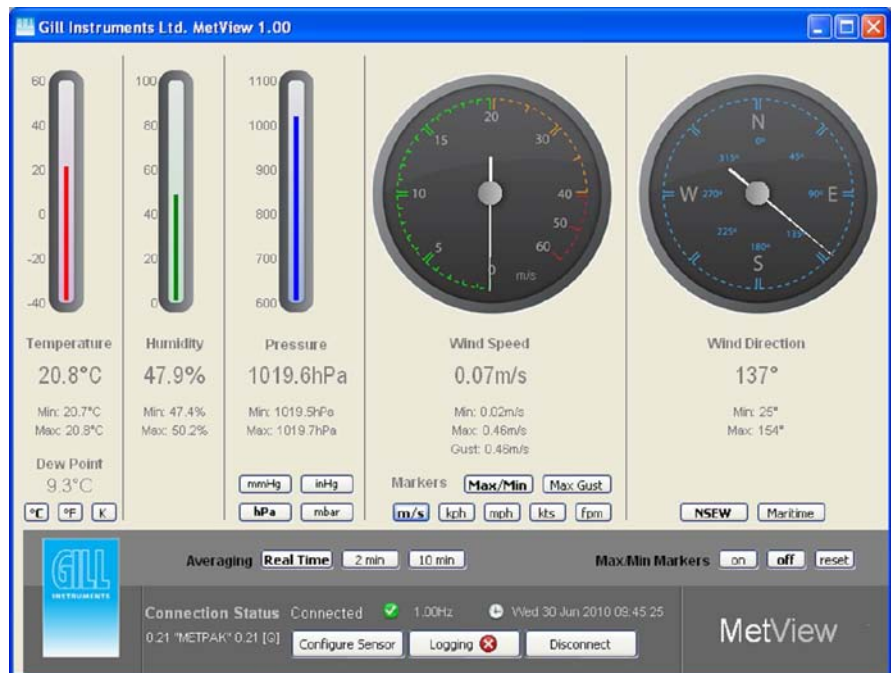



2. Installation

MetPak II has been designed to meet and exceed the stringent standards listed in its specification (see para 6.1).

2.1 Pre-Installation Checks

As with any sophisticated electronics, good engineering practice should be followed to ensure correct operation:

- Ensure the MetPak II will not be affected by other equipment operating locally, which may not conform to current standards, e.g. radio/radar transmitters, generators etc.
- Avoid mounting in the plane of any radar scanner – a vertical separation of at least 2m should be achieved.
- When installing MetPak II near radio transmitting antennas, ensure that the mounting position fulfills the following minimum separations (all round):
 - VHF IMM – 1m
 - MF/HF – 5m
 - Satcom – 5m (avoid likely lines of sight)
- Use cables recommended by Gill (see page 8). If cables are cut and re-connected incorrectly (perhaps in a junction box) then EMC performance may be compromised if cable screen integrity is not maintained.
- Avoid earth loops – wire the system in accordance with these installation guidelines.
- Ensure that the power supply operates to the MetPak II specification (see para 6.1) at all times.
- Avoid turbulence caused by surrounding structures that will affect the accuracy of the sensors such as trees, masts and buildings. The WMO make the following recommendations. The standard exposure of wind instruments over level open terrain is 10m above the ground. Open terrain is defined as an area where the distance between the sensor and any obstruction is at least 10 times the height of the obstruction.
- Keep away from building exhaust vents, machinery and motors.

2.2 Installation

2.2.1 Bench system test



Prior to physically mounting the MetPak II in its final location, we strongly recommend that a bench system test is carried out to confirm the system is configured correctly, is fully functional and electrically compatible with the selected host system and cabling (preferably utilising the final cable length). The required data format, units, output rate, and other options should also all be set up at this stage.

2.2.2 Equipment Required

- 1723-PK-100 MetPak II set for RS232 communication (factory default setting).
 - 1723-10-051 MetPak II RS232 to USB 1.8M configuration cable with integral 5v power or alternatively use RS232, RS232 converter and separate 5v to 30 dc power supply.
 - ES-U-1001-A EasySynch RS232 to USB adaptor or equivalent (if not using Gill part 1723-10-051) or connect directly to an RS232 COM port.
- Power Supply 5V to 30Vdc at 50mA if required.
- Belden 9503 3 pair cable (if not using Gill Part 1723-10-051), length as required.
- Gill MetView Software supplied on the MetPak II CD or download from <http://www.gill.co.uk/main/software.html>

2.2.3 Cabling

MetPak II has five communication connection options:

- USB (using the 1.8m Gill USB cable, Part No. 1723-10-051).
- RS232
- RS422
- RS485 (two wire point to point)
- SDI-12

It is important that the cable is appropriate for the chosen communication network. The following sections describe the recommended types and maximum lengths of cable in each case.

NOTE. A 15-metre, 6-pair cable (wires stripped at each end) suitable for RS232/RS422/485 or SDI-12 communication is available from Gill Instruments (Part No. 1723-10-053).

Cable Type

- Wire type:** 24AWG
- Wire size:** 7x32 AWG.
- Cable outer diameter:** 6-8mm (to match the hub box gland).

For RS422/485 operation the cable should contain twisted pairs screened to match the application.

The following table shows an example manufacturers' reference; other manufacturers' equivalents can be used.

Table 2 Recommended Belden cable types

Application	No. of Pairs	Belden Ref.
SDI-12 or RS485	2	9729
Digital RS232	3	9503
Digital RS422	4	9504

Cable length

The maximum cable length is dependent on the chosen communication method.

The following table shows the maximum cable lengths for the supported communication protocols at the given baud rates, using the recommended cable. If any problems of data corruption etc are experienced, then a slower baud rate should be used. Alternatively, a higher specification cable can be tried.

Table 3 Maximum cable lengths for supported communication networks

Communication format	Baud rate	Max. cable length
RS232	19200	6.5M
RS422/RS485	19200	1000M
SDI-12	1200	90m (300ft)

Cabling protection

The Cable should be secured:

- With cable clamps or equivalent at regular intervals such that the hub box cable gland does not support the cable weight.
- Away from the mounting U bolts to prevent chaffing of the cable.



NOTE. Install appropriate strain relief support to the cable. If possible, pass the cable through the mounting pole.

Earthing

To ensure correct operation and for maximum protection from lightning, a separate lightning rod system is recommended to protect the system.

You can also earth the MetPak II through its mountings or by connecting a grounding cable (minimum of 6mm² copper wire) to a spare MetPak II metalwork bolt hole. Clean off any paint that might prevent a good connection.

When you connect the communications cable ensure that the screen wires are attached to the terminal post in the hub box (see Figure 4).

2.2.4 Communication connections

To connect MetPak II:

1. Open MetPak II's hub box by unfastening the four screws.
2. Locate connector J5 (see Figure 4). Carefully pull the connector off its circuit board pins.
3. Strip the cable wires to 8mm.
4. Pass the cable through one of the gland nuts.
5. Connect your cable as shown in the following diagrams:
 - Gill USB Cable Figure 5
 - RS232 Figure 6
 - RS422 Figure 7
 - RS485 Figure 8
 - SDI-12 Figure 9
6. Attach the cable's screen wires to the terminal post (see Figure 4).
7. After connection, securely tighten the gland nut to prevent moisture ingress.



NOTE. Ensure that MetPak II is configured for the chosen communications method.

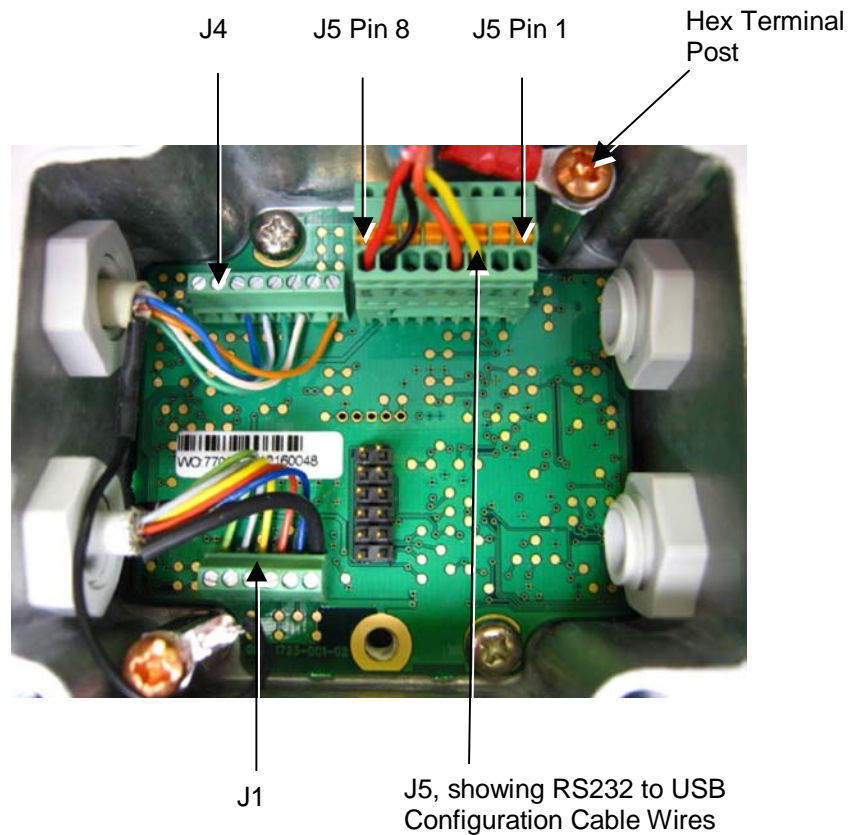
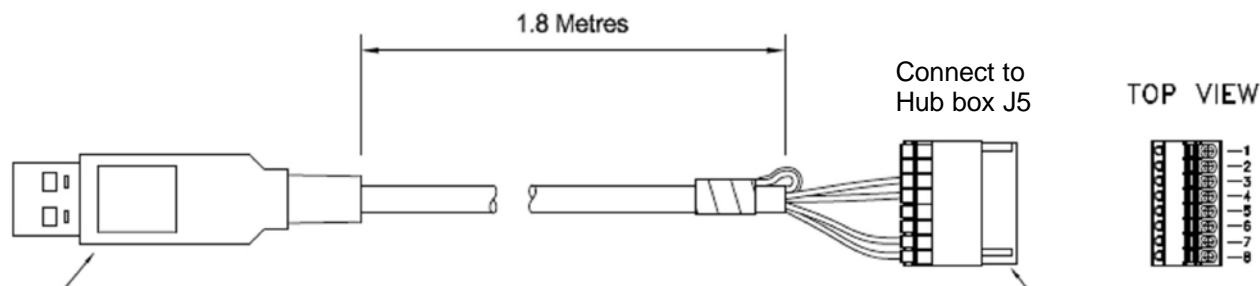

Figure 4 Internal view of the hub box

USB Lead Connection (COMMS set for RS232)



Connect MetPak II to a PC USB port using the Gill Configuration Cable 1723-10-051.

J5 Pin	1	2	3	4	5	6	7	8
Colour	None	None	Yellow	Orange	None	None	Black	Red

Figure 5 Connection of Gill USB Cable (Part No. 1723-10-051)

Digital Output RS232 Connections (COMMS set for RS232)

This is the MetPak II default communication configuration setting.

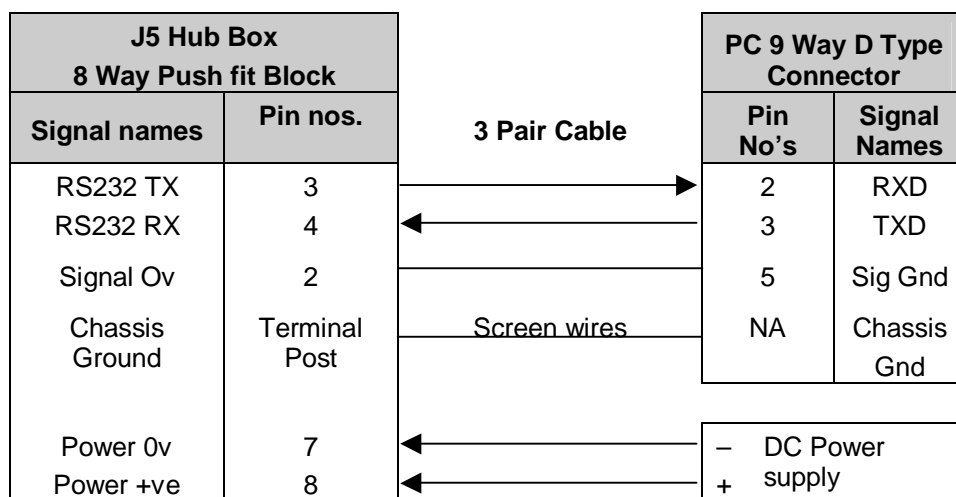

Figure 6 RS232 connections

Digital Output RS422 Connections (COMMS set for RS422)

This is not the default communications setting; ensure the MetPak II has been configured for this output requirement before wiring to a user device.

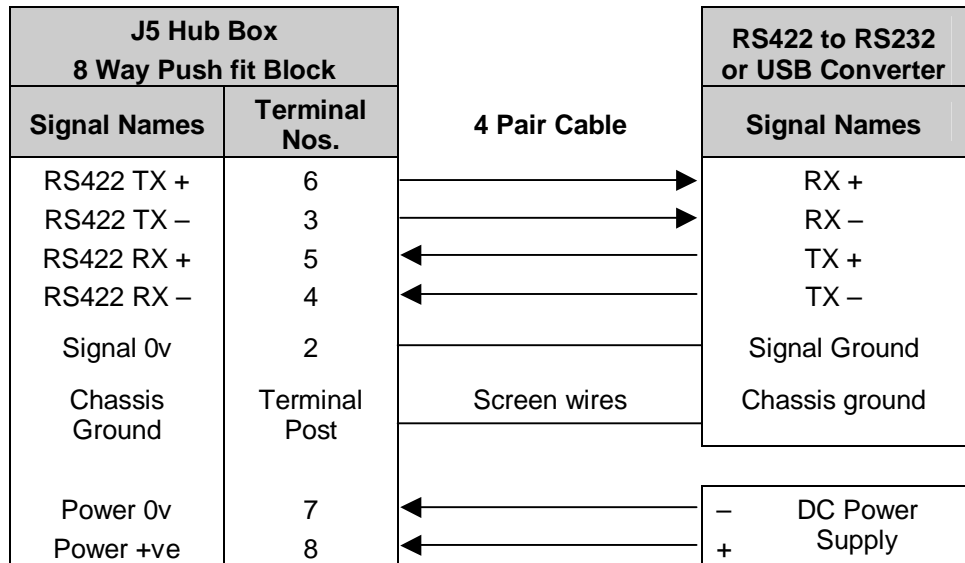

Figure 7 RS422 connections

Digital Output RS485S 2 Wire Point to Point Connections (COMMS set for RS485P2W)

This is not the default communications setting; ensure the MetPak II has been configured for this output requirement before wiring to a user device.

Note that is not possible to network other devices on this 2-wire RS485 link.

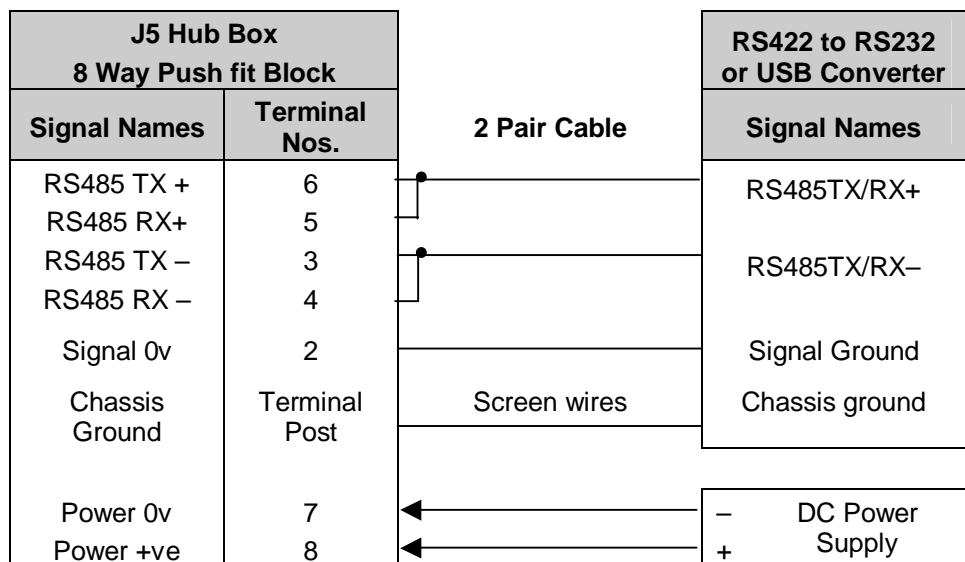

Figure 8 RS485 Connections

Digital Output SDI-12 Connections (COMMS set for SDI12)

This is not the default communications setting; ensure the MetPak II has been configured for this output requirement before wiring to a user device.

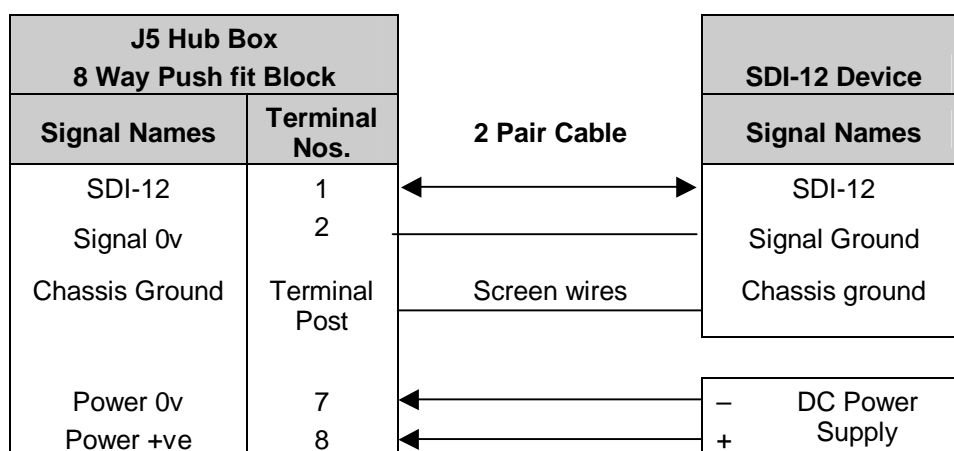

Figure 9 SDI-12 connections

2.2.5 Mounting MetPak II

MetPak II uses a U-bolt mounting clamp suitable for attaching to a vertical pipe with a diameter of 25-50mm. When mounting MetPak II, consider the position, orientation and alignment of the unit.

Position

It is the responsibility of the customer to ensure that the MetPak II is mounted in a position clear of any structure, including the mounting post, which may obstruct the airflow or induce turbulence.



CAUTION. Do NOT mount the MetPak II in close proximity to high-powered radar or radio transmitters. A site survey may be required if there is any doubt about the strength of external electrical noise.

The temperature and humidity probe is mounted inside the radiation shield as shown in Figure 3.

Orientation

Normally, the MetPak II is mounted on a vertical pole, ensuring a horizontal Measuring Plane, (see Figure 10 Correct mounting position for MetPak II

For indoor use the unit may be mounted with the Measurement Plane set to any required orientation.

Alignment

The MetPak II should be aligned to point to North, or any other reference direction –for example, the bow of a boat.

There are two arrows, a coloured rectangle, and an alignment notch to aid alignment.



Note. It is usually simpler to work first with a compass at ground level and identify a suitable landmark and it's bearing.

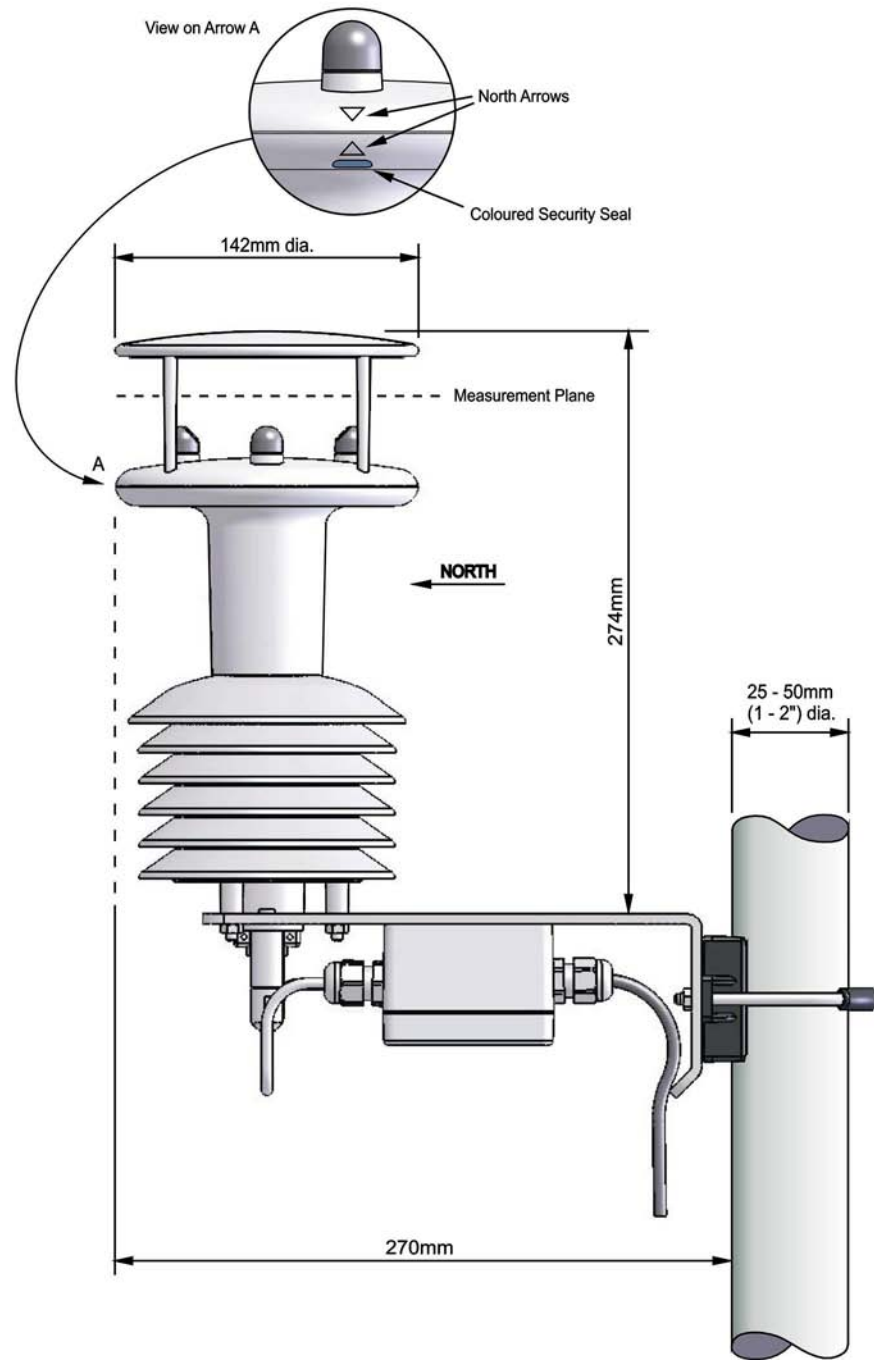

Figure 10 Correct mounting position for MetPak II



3. Operation

There are several ways in which you can retrieve weather information from the MetPak II:

- MetView (Graphically View Data and Log)
- Using MetSet or an MS Windows Terminal (both to View Data and Configure the MetPak II)
- SDI-12 command set (Retrieve Data)

3.1 MetView

Before you can use MetView, check that MetPak II is correctly connected to a COM or USB port on your PC (see page 11).

3.1.1 Opening MetView

Click on the MetView button on your PC's desktop or choose:

Start > Programs > MetView > MetView

The MetView Control Centre window is displayed. If you have more than one MetPak II connected to your PC, MetView, by default, connects to the first device detected. If you want to choose which device to monitor, clear the *Connect to first device found* box.



Figure 11 Opening MetView Screen

3.1.2 Scanning for Devices

To set up communicate between MetView and a connected MetPak II:

1. Click on the **Scan** button to search the available COM ports for MetPak II devices.

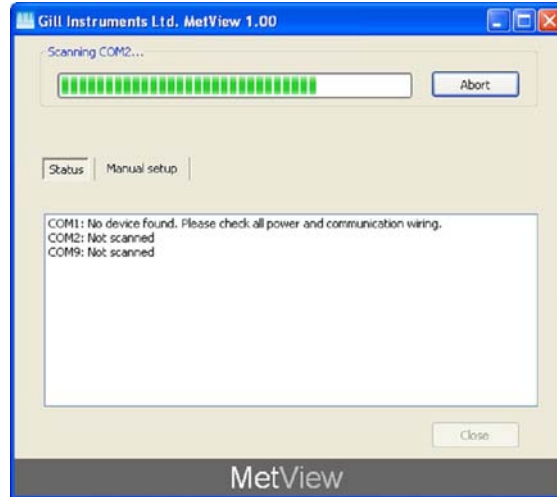

Figure 12 Scanning for MetPak II Devices

When a device is found, MetView displays the console (see Figure 13), obtains the MetPak II configuration settings and then retrieves and displays MetPak II data.

3.1.3 The MetView Console

When connected correctly, MetView displays its data-monitoring console. This consists of five gauges showing: Temperature, Humidity, Pressure, Wind Speed and Wind Direction. There is also a digital readout of Dew Point. Buttons beneath each of the gauges allow you to choose the displayed units and other options. Each gauge also shows the maximum and minimum values recorded during the current session. The wind speed gauge also shows the maximum gust speed.

Note: MetView will not show data if the unit is set for NMEA or SDI-12 formats.

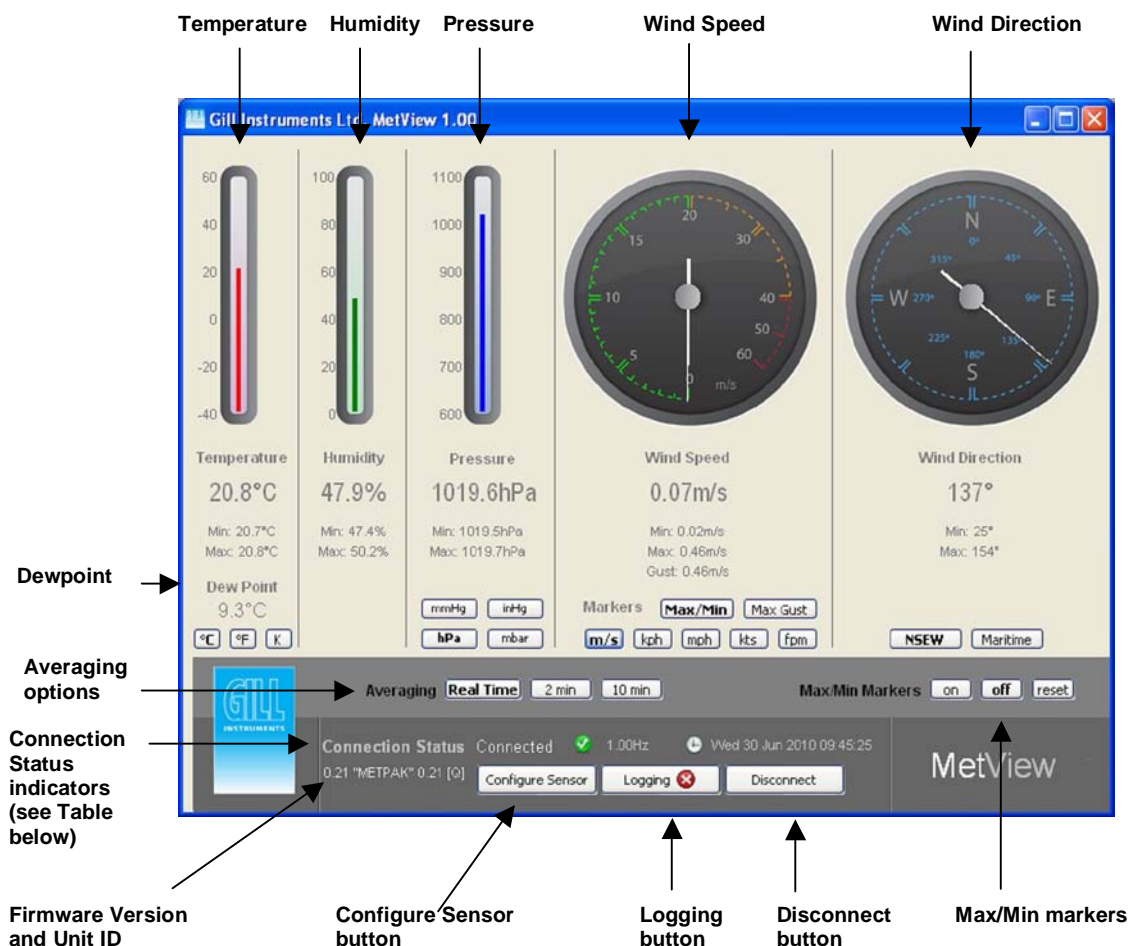

Figure 13 The MetView Console

Connection Status

Table 4 Connection status indicators

Reading	Function
Green Background Tick	Indicates MetPak II logging or communicating correctly with MetView along with reading the MetPak II firmware version.
Red Background Cross	Indicates MetPak II not logging or connected/communicating to MetView.
1.00Hz	Indicates the output rate of the MetPak when connected. Reads when the unit is communicating correctly with MetView.
Wed 30 Jun 2010 09:45:25	Real Time PC date and time indication.

3.1.4 Console Display Options

MetView Console buttons can convert data from the MetPak II to read different units or scale settings. This does not alter the actual MetPak II configuration.

Units shown in **bold** denote default settings

Table 5 MetView scale and unit options

Gauge	Function
Temperature & Dew Point	Use buttons to choose from three temperature scales: °C, °F, K
Humidity	Displays Max and Min values during current session in %
Pressure	Use buttons to choose from pressure scales: hPa , mbar, inHg, mmHg
Wind Speed	Use buttons to choose from five wind speed units: m/s , kph, mph, kts, fpm
Wind Speed Markers	Use buttons to add markers on the gauge for Max/Min or Max Gust.
Wind Direction	Use buttons to choose from two display styles: NSEW or Maritime

Table 6 MetView averaging options

Setting	Function
Real Time	Choose this button for no averaging
2 Min	Select for 2 minute rolling average of all sensor readings
10Min	Select for 10 minute rolling average of all sensor readings

Table 7 Max/min markers

Setting	Function
Off	Maximum and Minimum Markers on all gauges turned off
On	Maximum and Minimum Markers on all gauges turned on
Reset	Reset all Gauge Maximum/Minimum Markers and all digital Maximum/Minimum reading at will

3.1.5 Define Configuration Settings

The firmware and unit identification node letter (e.g. Q) is displayed on the MetView Console screen (bottom left).

1. To identify the data string format and units of measurement:
2. Click on the **Configure Sensor button** on the MetView Console display. The *Configure Sensor* window is displayed.



Figure 14 The Configure Sensor screen

3. Click on the **Define rx format** button. The *Reporting Format* dialog box is displayed. This shows the string format, string units and the order of the data string.

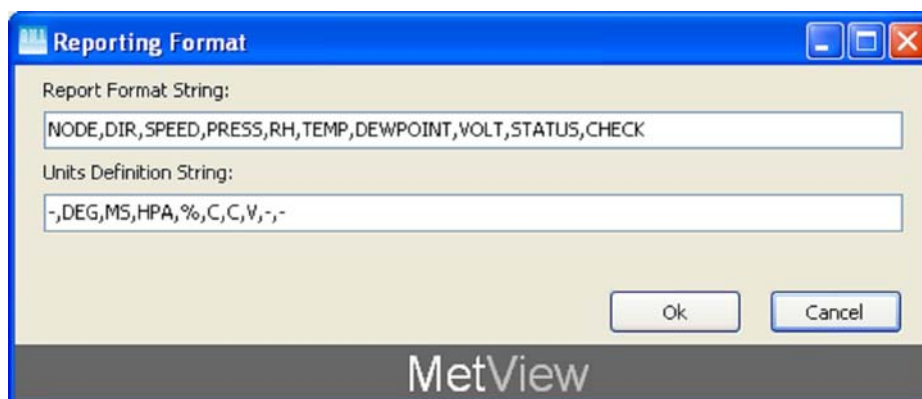

Figure 15 Reporting Format

4. Click on the **OK** button or on the **Cancel** button to return to the *Configure Sensor* screen.
5. Click on **View Display** to return to the MetView Console.

3.1.6 Data logging



NOTE. MetView logs data based on the MetPak II configuration not on the MetView console settings.

To log MetPak data, click on the **Logging** button on the MetView console. The *Logging* dialog box is displayed.

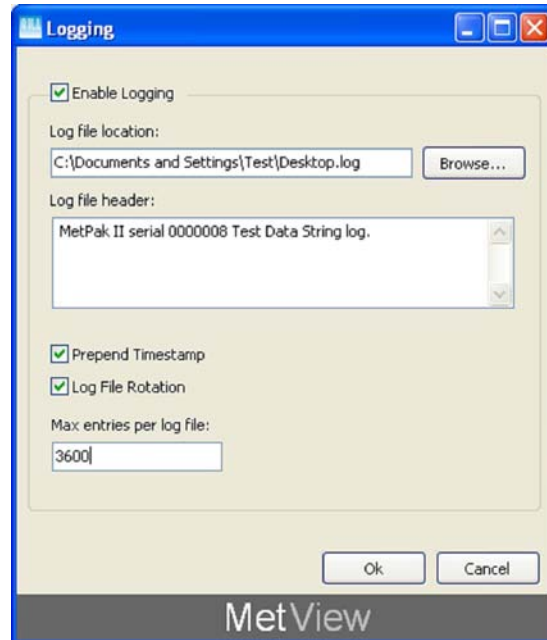

Figure 16 Setting up data logging

Setting up a logging file

1. Select **Enable Logging** to start logging to a file.
2. Identify the name and location for the logging file:
 - Log File location** Click on the **Browse** button to identify the folder where you want to store the data file. Enter the name of the file.
 - Log file header** If required type some notes on the data that is to be recorded which will appear at the top of the saved data log file.
3. Choose from the following additional options:
 - Prepend Timestamp** Adds the date and time to the logged data file.
 - Log File Rotation** Set up segmented logging with each logged file length determined by the number entered in the text box below. The figure 3600, for example, means that each log file length will be 3600 lines of data.

To start logging

1. Check that the **Enable Logging** option is selected.
2. Click on the **OK** button to commence logging and return to the console.



Note. To show that data is being recorded, the Logging button's icon changes to a green tick:



To stop logging

To turn off logging:

1. Click on the **Logging** button on the MetView console. Clear the **Enable Logging** check box.
2. Click on the **OK** button. If logging has stopped, the Logging button shows a red background cross instead of the green background tick (see above).

Understanding logged data

Logged data is stored to a file with a **.log** extension. This can be viewed in any text/HTML editor or spreadsheet application.

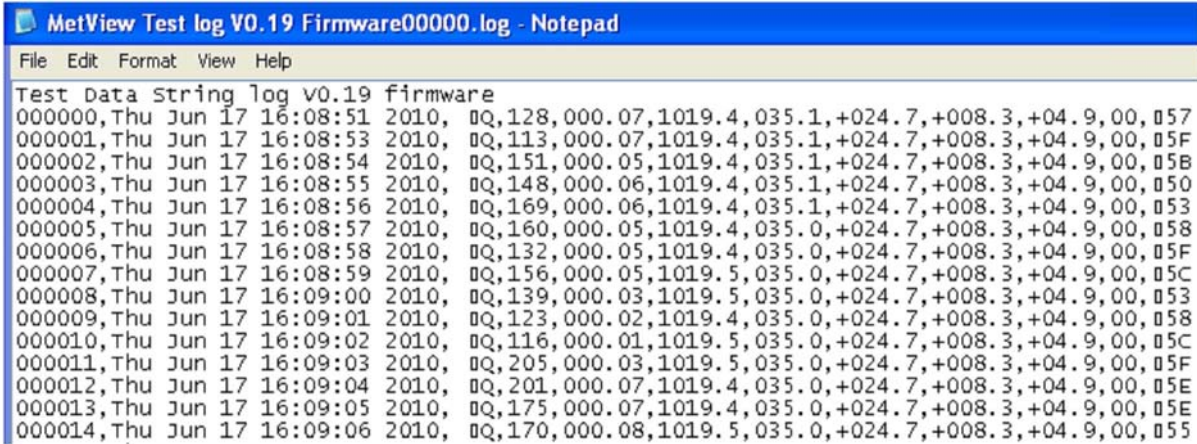
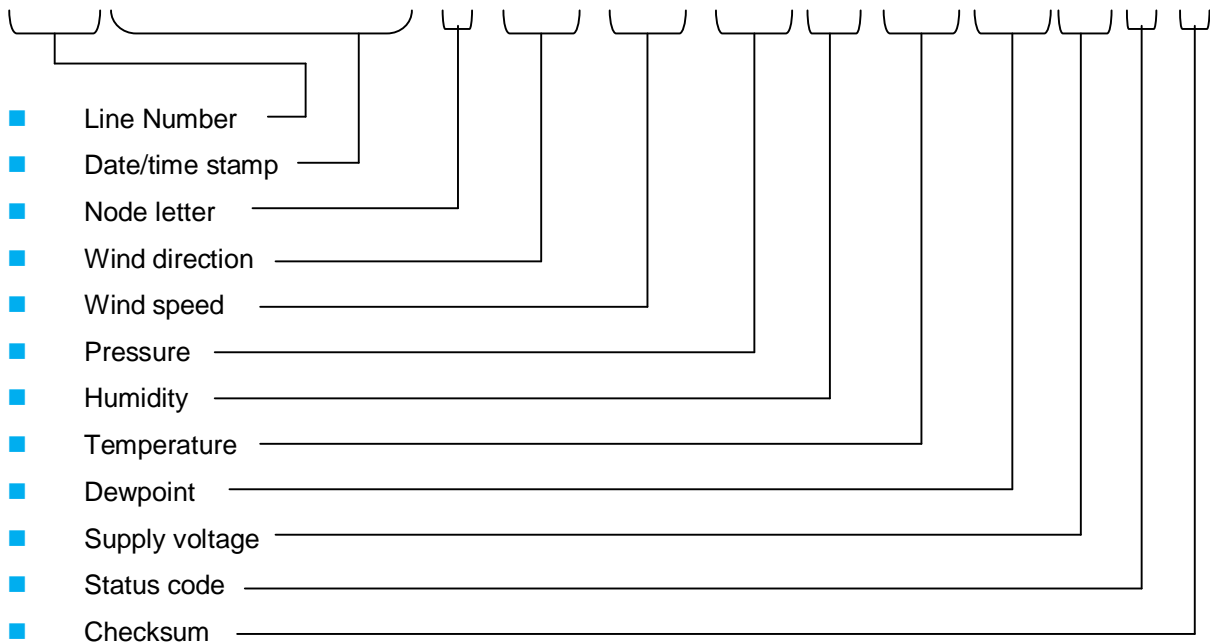

Figure 17 A typical data log (viewed in Windows Notepad)

Each entry in the default file format consists of the following:

000001 Thu Jun 17 16:08:53 2010, 0Q, 113, 000.07, 1019.4, 035.1,+024.7,+008.3,+04.9,00,05F



3.2 Configuring MetPak II

MetPak II can be configured using:

- Gill MetSet or a terminal program such as Windows HyperTerminal.
- Gill Wind software used as a Terminal Program only.

The default configuration settings are listed in the following table.

Table 8 Default configuration settings

Setting	Function
Comms Levels	RS232
Baud Rate	19200
Data Connection	Data Bits 8, Parity None, Stop Bits 1, Flow Control None.
Output rate	1Hz
Message Mode	Continuous
Message Format	Wind Direction (degrees), Wind Speed (Metres/Sec), Barometric Pressure (hecto pascals), Humidity (percent), Temperature (degrees C), Dew Point (degrees C), Power Supply (volts), Status Code (00) Checksum (hex number).
Output Sentence	Comma Separated Variable
Node Address	Q
Message terminator	Carriage return and line feed.
Power up message	On

Example Default ASCII Data String:

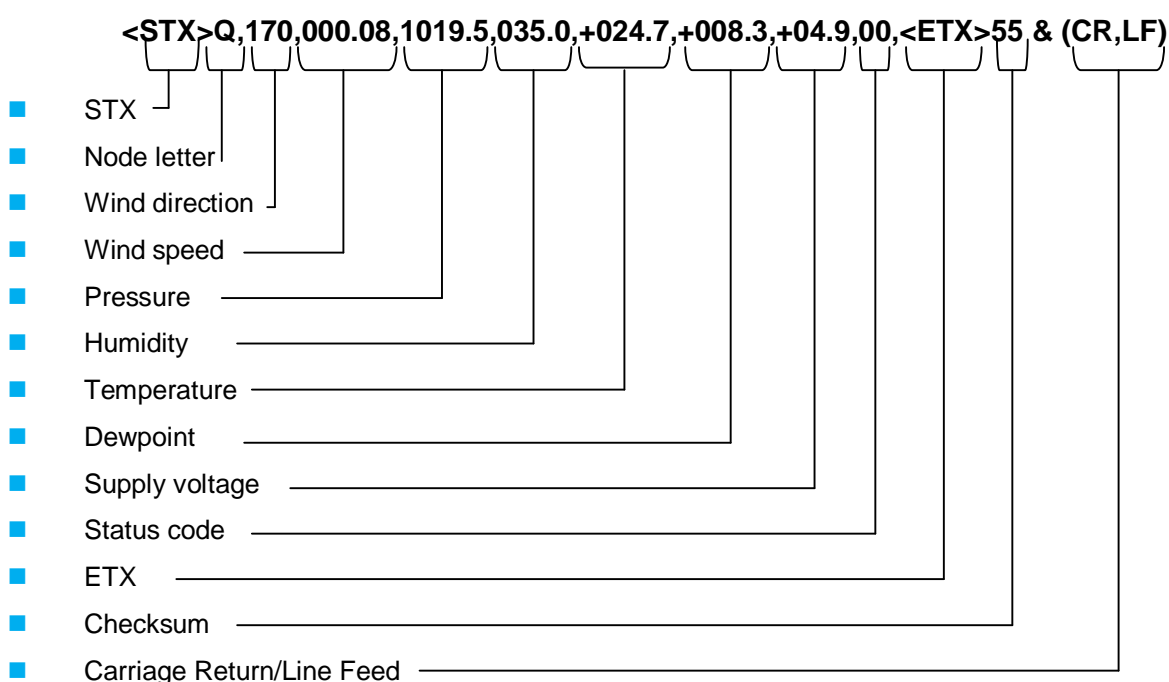

NOTES:

<STX> is the Start of String character (ASCII value 2).

<ETX> is the End of String character (ASCII value 3).

Checksum, the 2 digit Hex Checksum sum figure is calculated from the Exclusive OR of the bytes between (and not including) the STX and ETX characters.

3.2.1 Configuring MetPak II using MetSet

Before you use MetSet check that MetPak II is correctly connected to a COM or USB port on your PC.

Click on the MetSet button on your PC's desktop or choose:

Start > All Programs > MetSet > MetSet

The MetSet Control Centre window is displayed. If you have more than one MetPak II connected to your PC, MetSet, by default, selects the first device detected.

For most applications it is recommended to click on the MetSet **Connect and Read** button.

MetSet interrogates the MetPak II and returns a summary of the device settings (takes approximately 1 minute).

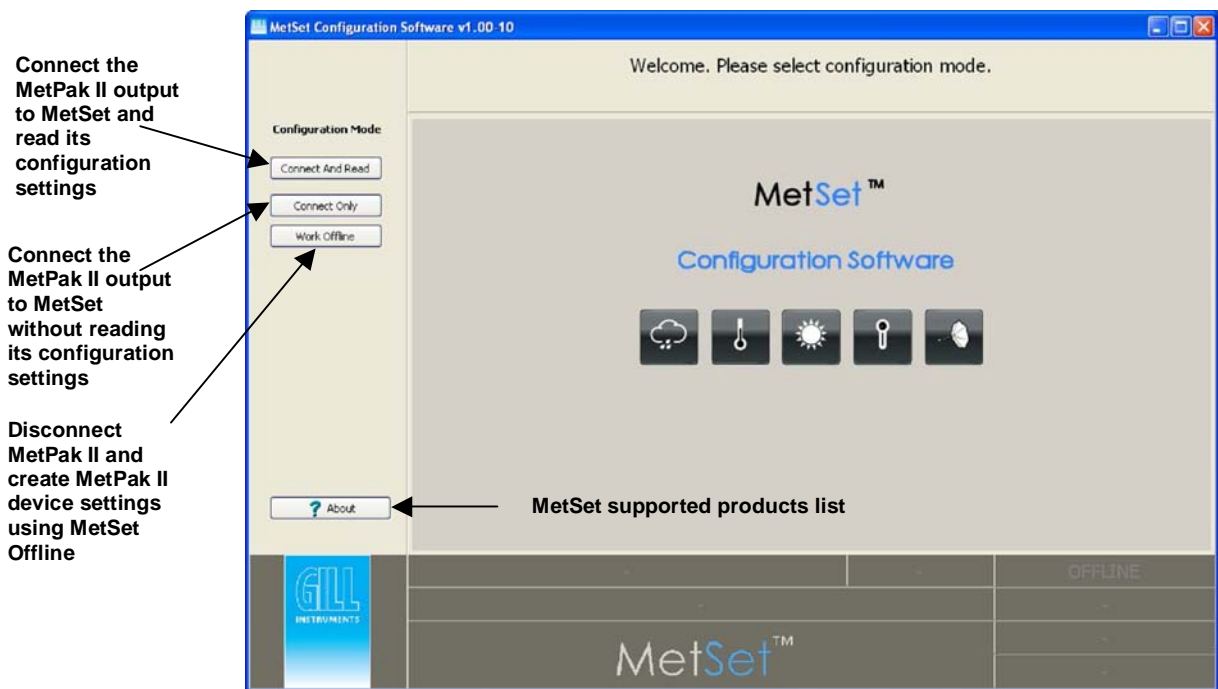

Figure 18 Opening MetSet Screen

Summary of Device Settings Screen

Note that MetSet also saves a copy of this screen to the connected PC as a Session Report File that can be accessed from the following destination.

C:\Program Files\Gill Instruments\MetSet\SessionReports

Close Summary of Device Settings screen to go to the Editing screens.

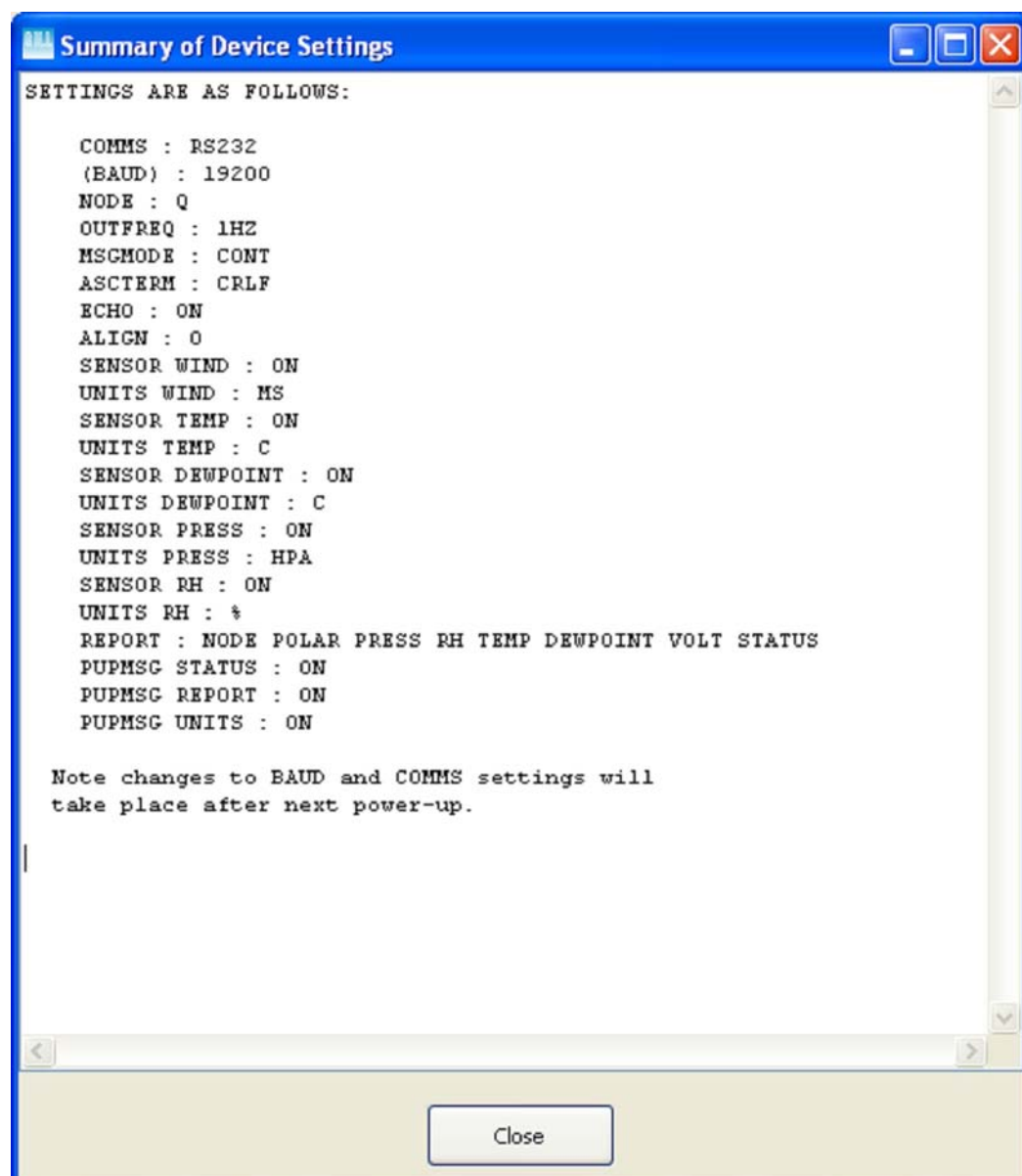

Figure 19 Summary of MetPak II Device Settings using MetSet

3.2.2 MetSet Editing Screen

When connected correctly a MetSet editing screen is available to read configuration settings, change configuration settings, save MetPak II configuration settings to a PC file location, upload MetPak II configuration settings from a PC file and view the MetPak II raw data string output,

MetPak II Editing Screens

MetPak II Device Setting Options

View MetPak II Raw Data Output String

Return to opening MetSet Screen

Move mouse over exclamation or question marks to read setting comment

Firmware Version and Unit ID

Source of MetSet Data

Serial Number

Connection Status

MetSet Connection Status Information.

Reading	Function
2436 'METPAK II' 2.00 [Q] PV=1	2436 is the MetPak II Firmware number 2.00 is the firmware revision. [Q] is the unit identifier. PV=1 is the Protocol Version (Gill internal reference).
S/N:12345678	MetPak II serial number.
ONLINE	ONLINE in green indicates the MetPak II has been successfully connected to MetSet. OFFLINE in Grey indicates that MetSet is being used without a MetPak II in communication with MetSet.
Source:Device	MetSet reads 'Device' when the source of the data that MetSet has retrieved has come from the MetPak II. MetSet reads 'File' when the source of data has come from a saved file.
19200 COM 10	19200 is a report on the MetPak II Baud rate setting. COM 10 is a report on the MetPak II COM Port connection number.
Device: METPAK II	MetSet reports on the connected device (MetPak Pro or MetPak II)

MetSet Online Mode Settings.

Online Mode Buttons	Function
Get Device Settings	MetSet retrieves the MetPak II Configuration settings.
Save Settings To Device	MetSet configuration settings are saved to a connected MetPak II.
Save Configuration File	When selected MetSet edit settings are saved to a PC file location.
Load Configuration File	When selected MetSet retrieves a MetSet edit PC file and updates MetSet with these settings.
Back Up Device Settings	When selected the MetPak II configuration settings are transferred to MetSet and then to a file location selected on a PC.
Restore Device Settings	When selected MetSet retrieves a MetPak II configuration setting from a PC file, loads it into the MetPak II and updates the MetSet edit settings.
Measurement Mode View Output	Click on View Output to view the raw ASCII MetPak II data string scrolling at the output rate. (View only feature). E.g. □Q,014,000.06,1011.2,042.1,+023.0,+009.4,+12.0,00,□40
X Main Menu	Click here to go back to the opening MetSet screen

MetSet Editing Screens.



Editing Screens	Function
Comms	Use to read or change Comms Interface, Baud Rate, Node ID, Output Rate and Message Mode. NOTE: When COMMS or BAUD settings are changed and Saved to Device a warning is issued by MetSet. These setting changes will not become active until the MetPak II power is turned off and then turned on again. The connecting device will then also need its Comms and Baud rate settings changed to match the MetPak II.
ASCII Set Up	Use to read or change message Termination and Echo
Wind	Use to read or change North Alignment (0-359 degrees), Sensor WindSpeed on or off and Wind Units of measure.
Temperature	Use to read or change Temperature sensor on or off and units. Dewpoint sensor on or off and units.
Pressure	Use to read or change Pressure sensor on or off and units.
Humidity	Use to read or change Humidity sensor on or off and units.
Reporting	Selects Output Format (Full, User, NMEA) and Output Parameters (Node, Polar, Axis, Pressure, RH, Temp, Dewpoint, Volts, Status) either on or off and in the order required in the data string.
PowerUp	Use to read or change reporting the status message, report message, units message, inputs message to on or off.
Save Edited Screen Settings to MetPak II	Click on 'Save Settings to Device' this will change the MetPak II configuration to reflect the new MetSet settings. (Note this may take 1-2 minutes to complete).

3.2.3 Configuring MetPak II using HyperTerminal



NOTE. This section describes the procedure using Windows HyperTerminal. There are many equivalent terminal emulators that you could use and the procedure will be similar: identify the COM port for the connection and configure the port settings as described in step 6.

Setting Up HyperTerminal

To configure MetPak II using HyperTerminal:

1. Select an available Com port and connect the MetPak II unit.
2. Run **Hypertrm.exe**
(Typically accessed via Start | All Programs | Accessories | Communications | Hyperterminal).
3. Select **New Connection** from the **File** menu.
4. Enter a name for the connection, for example *MetPak II* and, optionally, select an icon to represent it. Click on the **OK** button.
5. In the *Connect To* dialog box, change *Connect Using to COMX* (where X is the number of the selected COM port). Click on the **OK** button.
6. In the *COMX Properties* dialog box, adjust the *Port settings* to match the MetPak II unit's settings. The default settings are :

■	Bits per second	19200
■	Data bits	8
■	Parity	None
■	Stop bits	1
■	Flow Control	None
7. Click on the **OK** button.

Message Reporting

MetPak II has two reporting modes:

- Continuous mode

In continuous mode (the default) Metpak II reports continuously. So, if you have set up the connection correctly, you should now see data strings scrolling across the HyperTerminal window. For example:

Q,113,000.07,1019.4,035.1,+024.7,+008.3,+04.9,00,□5F

- Polled mode

If the unit has been set to polled mode (see MSGMODE command in Table 9), type ?Q (where Q is the unit node letter) to prompt one line of the data string.

Entering MetPak II's setup mode

To enter the unit's setup mode:

- If the unit is in continuous reporting mode, type *.
- If the unit is in polled mode, type *Q (where Q is the unit node letter).

The MetPak II unit stops reporting sensor measurements and reporting (if in continuous mode) and responds with the following message:

SETUP MODE

The unit is now ready to receive configuration commands.

Returning to measurement mode

To exit from the setup mode and return to the reporting mode:

Type **Q** and press **Enter**.

The MetPak II unit returns to measurement mode and begins reporting (if set up for continuous mode).

Configuring commands for MetPak II

The following table lists the full set of commands for configuring MetPak II.

Table 9 MetPak II configuration commands

Command	Parameters	Description and examples
*	*	Used to place the unit into a SETUP mode so that User Commands may be sent to change unit settings.
*A-Z	*A Z	If the unit is in Polled mode this command is used to place the unit into a SETUP mode so that User Commands may be sent to change unit settings. Where Q is the default node letter but may be set between A to Z.
?	?	Used when the unit is configured for Polling and enables Polling.
?A-Z	A ?B to ?Z	Retrieves a line of data from a MetPak II set for Polled mode with a Node identifier set to A to Z Note. In Polled mode the unit MUST be allowed 5 seconds to be operational before the ? is used to enable polling, or it will be missed. When polled, allow the unit 4 seconds to respond with a line of data.
ALIGN	0 359	Align, sets and reports the degree offset applied to wind direction data read from the MetPak II. ALIGN <no parameter> returns the current value ALIGN 0 Sets North Alignment to 0°.
ASCTERM	CR CRLF	Sets ASCII output string terminator. ASCTERM <no parameter> returns the current value ASCTERM CR - ASCII output string terminator is <CR>. ASCTERM CRLF terminator set to <CR><LF>.
BAUD	4800 9600 19200 38400 57600	Sets the serial interface baud rate. Selection must be confirmed with a letter B. Parity selection and duplex operation is optional BAUD <no parameter> returns the current value Example: to change 19200 baud to 4800 Baud: Type BAUD 4800 and press Enter. Change the terminal baud rate to 4800. Type B and press Enter. Completes the 4800 baud selection.
COMMS	RS232 RS422 RS485P2W SDI12	Sets the serial interface communication protocol. COMMS <no parameter> returns the current value. To change to RS422 operation: Type COMMS RS422 and press Enter. (the Comms setting will remain unchanged allowing further settings to be changed and data viewed until the system is powered down and restarted). NOTE: The hardware connections will need be changed to match the new Comms setting.
ECHO	OFF ON	Character echo can be enabled or disabled. If enabled, received characters are only echoed while in interactive mode. ECHO <no parameter> returns the current value.
EXIT		Used to change the unit from Configuration mode to Measurement mode (alternatively type Q or QUIT)
HELP		Lists commands that are currently available.
MSGMODE	CONT POLL	Sets the message reporting mode. MSGMODE <no parameter> returns the current value. MSGMODE CONT - messages reported continuously. MSGMODE POLL - messages only reported when requested by the user (polled mode - see "?" command).

Command	Parameters	Description and examples
NODE	A B C to Z	Sets the unit Node address for unit recognition or Polling. NODE <no parameter> returns the current value. NODE A sets unit Node to A etc.
OUTFREQ	1/4HZ 1/2HZ 1HZ	Sets the unit data output rate in continuous mode. OUTFREQ<no parameter> returns the current value. OUTFREQ 1/4HZ -sets the unit to output 1 reading every 4 seconds.
PUPMSG	STATUS ON OFF REPORT ON OFF UNITS ON OFF	Unit powers up in the state as define by parameter. PUPMSG (power up message) <no parameter> returns the current value, e.g. <i>STATUS, REPORT, UNITS</i> . PUPMSG STATUS - displays a firmware issue status message on power up e.g. <i>METPAK 2436 V2.00 STARTUP OK</i> PUPMSG STATUS OFF or ON- unit does not display (OFF) or does display (ON) a firmware issue status message on power up. PUPMSG REPORT - displays a header showing currently reported parameters e.g. <i>NODE,DIR,SPEED,PRESS,RH,TEMP,DEWPOINT,VOLT,STATUS,CHECK</i> PUPMSSG REPORT OFF or ON-unit does not display (OFF) or does display (ON) a header showing currently reported parameters. PUPMSG UNITS -displays a header showing the units of each field in the data output report. e.g. <i>-,DEG,MS,HPA,%,C,C,V,-,-</i> PUPMSG UNITS OFF or ON - does not display (OFF) or does display (ON) a header showing the units of each field in the data output report. NOTE. There is a power up message in polled mode unless turned off. Power up message, this is displayed when the unit is being powered up excepting if it has been deactivated. System should be fully operational inside 5 seconds.
Q or QUIT		Used to change the unit from Configuration mode to Measurement mode (see also EXIT)
REPORT	FULL NODE POLAR AXIS PRESS TEMP RH DEWPOINT VOLT STATUS NMEA.	Defines a reporting string. REPORT <no parameter> returns the current value, e.g. <i>NODE,DIR,SPEED,PRESS,RH,TEMP,DEWPOINT,VOLT,STATUS,CHECK</i> REPORT FULL - all instrument readings are output in the following default order: <input type="checkbox"/> Q,225,000.02,1023.4,041.8,+023.5,+009.8,+04.9,00,50 (Node, Direction, Wind Speed, Pressure, Humidity, Temperature, Dewpoint, Volts, Status, Checksum). REPORT NODE – reports the unit Node letter (default Q) REPORT POLAR -reports Polar Wind Speed, Polar Direction and Checksum only. REPORT AXIS - reports U Axis Wind Speed, V Axis Wind Speed and Checksum only. REPORT PRESS -reports Pressure and Checksum only. REPORT TEMP - reports Temperature and Checksum only. REPORT RH - reports Relative Humidity and Checksum only. REPORT DEWPOINT reports Dewpoint and Checksum only. REPORT VOLT - reports Supply Voltage and Checksum only. REPORT STATUS - reports MetPak II status codes and Checksum only. REPORT NMEA – reports Wind (WIMWV data), Temperature, Relative Humidity and Barometric pressure (WIXDR data) in NMEA 0183 format. The MetPak II data string can be set up in any order with the required sensor outputs. For instance, if it is required to output data in the order Pressure, Polar Wind, Temperature, Humidity, Status. Type REPORT PRESS POLAR TEMP RH STATUS and press Enter. Gives <input type="checkbox"/> 1023.4,319,000.05,+023.5,038.3,00,1D NOTE. A Hex Checksum figure will always be reported.

Command	Parameters	Description and examples
SENSOR		Command not used.
SERIAL		Used to report the MetPak II serial number. e.g. 00000008
SWVER		Returns the MetPak II Firmware version e.g. SWVER = 2436 V2.00
UNITS	WIND PRESS TEMP DEWPOINT RH	Valid values are dependent on sensor type. A UNITS command with no parameter shall display a line of test showing the selected units of the current output string. Changes the output units for an individual sensor. UNITS <no parameter> - returns the current value, e.g. e.g. UNITS = -,DEG,MS,HPA,%,C,C,V,-,- UNITS WIND MS - selects metres/second for the wind reading. UNITS PRESS HPA - Selects hectoPascals for the pressure reading. UNITS TEMP C - selects centigrade for temperature reading. UNITS DEWPOINT C - selects centigrade for dewpoint reading. UNITS RH % - selects percentage for relative humidity See Table 10 for a list of unit abbreviations.

Table 10 Abbreviations used in UNIT configuration command

UNITS measurement parameter	Unit	Abbreviation
WIND	Metres per Second	MS
	Nautical Miles per Hour	KNOTS
	Miles per Hour	MPH
	Kilometres per Hour	KPH
	Feet per Minute	FPM
TEMP and DEWPOINT	Celsius	C
	Fahrenheit	F
	Kelvin	K
PRESS	HectoPascals	HPA
	MilliBars	MB
	Inches of Mercury	INHG
	Millimetres of Mercury	MMHG
RH	Relative Humidity	%

3.2.4 Configuring MetPak II for NMEA Output.

To configure a MetPak II unit for RS422, 4800 Baud and NMEA 0183 output:

1. Place the MetPak II into SETUP MODE as described on page 30.
2. Type **REPORT NMEA** and press Enter.
3. Type **BAUD 4800** and press Enter.
4. Type **COMMS RS422** and press Enter. Until the unit is restarted, the COMMS setting will remain unchanged.
5. Shut down the MetPak II unit.
6. Change the hardware connections for RS422.
7. Restart the MetPak II unit.

An example NMEA data string produced at the output rate (default every 1Hz):-

```
$WIMWV,008,R,000.09,N,A*0C
$WIXDR,C,+023.0,C,TEMP,P,1.0199,B,PRESS,H,039.6,P,RH*33
```

The NMEA data string comprises of: -

```
<STX>,$WIMWV,008,R,000.09,N,A*0C,<ETX>,<CR>,<LF>
Where: -
```

\$WIMWV	Wind Instrument Mean Wind direction and Velocity
008	Wind Direction
R	Wind Measurement Relative to the North Marker
000.09	Wind Speed
N	Knots (NMEA output fixed to Knots measurement only)
A	Acceptable measurement (V is a void fail measurement)
0C	Hex CheckSum

And

```
<STX>$WIXDR,C,+023.0,C,TEMP,P,1.0199,B,PRESS,H,039.6,P,RH*33,<ETX>,<CR><LF>
```

Where: -

\$WIXDR	Wind Instrument Cross track error Dead Reckoning
C	Type of Sensor (Temperature)
+023.0	Temperature Reading
C	Temperature Reading in Degrees Centigrade
TEMP	Name of Temperature Sensor
P	Type of Sensor (Pressure)
1.0199	Pressure Reading in Bars.
B	Pressure Units of Measure (Bars)
PRESS	Name of Pressure Sensor
H	Type of Sensor (Humidity)
039.6	Humidity Reading in Percent
P	Humidity Units of Measure (Percent)
RH	Name of Relative Humidity Sensor
33	Hex CheckSum

<STX> is the Start of String character (ASCII hex value 2)

<ETX> is the End of String character (ASCII hex value 3)

<CR> is a Carriage return character (ASCII hex value d)

<LF> is a Line Feed Character (ASCII hex value a)

Checksum, the 2 digit Hex Checksum sum figure is calculated from the Exclusive OR of the bytes between (and not including) the STX and ETX characters.

3.2.5 Configuring MetPak II for SDI-12

To configure a MetPak II unit for SDI-12:

1. Place the MetPak II into SETUP MODE as described on page 30.
2. Type **COMMS SDI12** and press Enter. Until the unit is restarted, the COMMS setting will remain unchanged.
3. Shut down the MetPak II unit.
4. Change the hardware connections for SDI-12.
5. Restart the MetPak II unit.

3.2.6 SDI-12 Commands

SDI-12 Command Summary

- ?! Unit Address (default is 0).
- aAb! Change unit address (a = 0)
- aM! Wind Direction/Speed (direction in Degrees, speed in Metres/Sec), Temperature (degrees C), Pressure (Hecto Pascals/millibars) and Humidity (%).
- aM1! Wind Direction/Speed (direction in Degrees, speed in Metres/Sec), Temperature (degrees C), Pressure (Hecto Pascals/millibars) and Dewpoint (degrees C).
- aM2! Wind Direction/Speed (direction in Degrees, speed in Metres/Sec) and a 2 digit Status Code.
- aM3! Temperature (degrees C), Pressure (Hecto Pascals/millibars), Dewpoint (Degrees C).
- aM4! Pressure (Hecto Pascals/millibars).
- aM5! For future use.
- aM6! For future use.
- aM7! For future use.
- aM8! For future use.
- aM9! Power Supply Voltage (Volts).
- aD0! Request a line of the above data.

SDI-12 Command Details

Command	Description	Response	Example
?!	Unit Address	a<CR><LF>	0<CR><LF>
aAb!	Change the unit address a = 0, the default. b = the new address.	b<CR><LF>	1<CR><LF>
aM!	Wind Direction/Speed (direction in Degrees, speed in Metres/Sec), Temperature (degrees-C), Pressure (Hecto Pascals/millibars) and Humidity (%).	attn<CR><LF> a is unit identifier. ttt is time in seconds. n is number of data values. Measurement command to retrieve a reading of the maximum time the MetPak II will take to complete a measurement, have data ready and the number of data values.	00055<CR><LF> 0 is unit identifier. 005 is 5 sec. measurement. 5 is the number of data readings (Direction, Speed, Temperature, Pressure and Humidity).
0D0!	Retrieve a line of the above data.	a<dir><mag><temp><pressure><humidity><CR><LF>	0+220+000.01+021.6+1013.0+041.9<CR><LF>
aM1!	Wind Direction/Speed (direction in Degrees, speed in Metres/Sec), Temperature (degrees C), Pressure (Hecto Pascals/millibars) and Dewpoint (degrees C).	attn<CR><LF>	00055<CR><LF>
0D0!	Retrieve a line of the above data.	a<dir><mag><temp><pressure><dewpoint><CR><LF>	0+357+000.03+021.6+1013.0+008.0<CR><LF>
aM2!	Wind Direction/Speed (direction in Degrees, speed in Metres/Sec) and a 2 digit Status Code.	attn<CR><LF>	00053<CR><LF>
0D0!	Retrieve a line of the above data.	a<dir><mag><status><CR><LF>	0+029+000.01+00<CR><LF>
aM3!	Temperature (degrees C), Humidity (%), Dewpoint (Degrees C).	attn<CR><LF>	00053<CR><LF>
0D0!	Retrieve a line of the above data.	a<temp><humidity><dewpoint><CR><LF>	0+21.6+041.0+0007.8<CR><LF>
aM4!	Pressure (Hecto Pascals/millibars).	attn<CR><LF>	00051<CR><LF>
0D0!	Retrieve a line of the above data.	a<pressure><CR><LF>	0+1013.0<CR><LF>
aM9!	Power Voltage (Volts)	attn<CR><LF>	00011<CR><LF>
0D0!	Retrieve a line of the above data.	a<voltage><CR><LF>	0+12.5<CR><LF>

3.2.7 Safe Mode

Summary

The MetPak II Safe Mode provides a means of recovering communication with the MetPak II whatever configuration setting may have been made. For instance if the unit has been set for SDI-12 operation Safe Mode can be used to change the communication option back to RS232, RS422 or RS485.

Connection

Connect the MetPak II for RS232 communication as detailed on Page 11, Figure 6.

Method

Configure the MetPak II using HyperTerminal:

Note at this stage the MetPak II supply to be switched off.

Run **Hypertrm.exe**

(Typically accessed via Start | All Programs | Accessories | Communications | Hyperterminal).

Select **New Connection** from the **File** menu.

Enter a name for the connection, for example *Test* and, optionally, select an icon to represent it. Click on the **OK** button.

In the *Connect To* dialog box, change *Connect Using* to *COMX* (where *X* is the number of the selected COM port). Click on the **OK** button.

In the *COMX Properties* dialog box, adjust the *Port settings* to match the MetPak II unit's settings. **The Safe Mode settings are :**

Bits per second	4800 (Note 4800 Baud rate setting)
Data bits	8
Parity	None
Stop bits	1
Flow Control	None

Click on the **OK** button.

A blank HyperTerminal screen will be opened.

Hold down the * key on the keypad.

With the * key still held down, apply power to the MetPak II.

This will result in placing the unit into SAFE MODE.

Press Enter to start a new line (Ignore illegal command line).

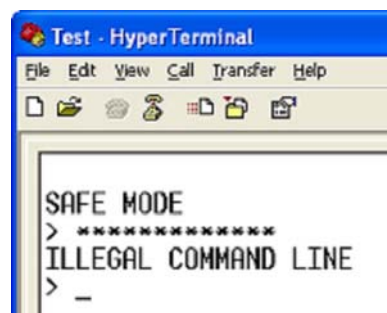

To now change communication from SDI-12 to RS232.

Type COMMS RS232 and press Enter.

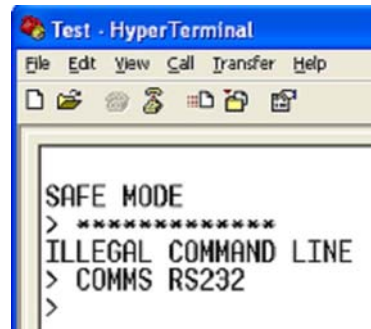

Type Q and press Enter to exit Safe Mode.

Data will now scroll on screen.

Note however for RS232 changes to take place the unit must be powered down and back up again.

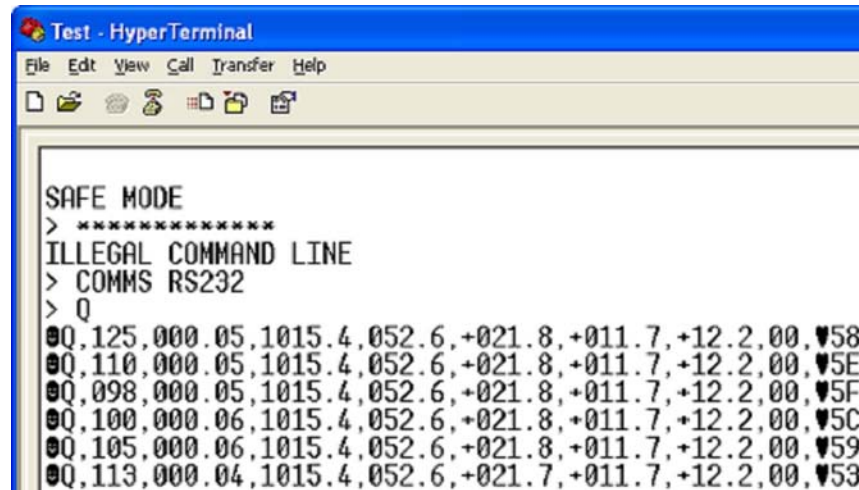

Close the 4800 baud rate HyperTerminal Program.

Power down the MetPak II and re-apply power.

Open a new HyperTerminal program at **19200 baud** rate.

RS232 data will now scroll on screen at the MetPak II default 19200-baud rate.

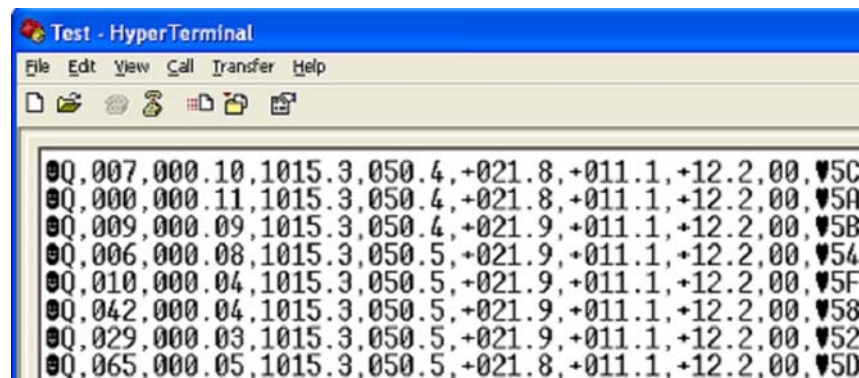

The * command can now be used if required to place the unit into SETUP mode and make any other changes to the MetPak II configuration.



4. Troubleshooting

4.1 Fault-Finding

Common Problems

Table 11 Common problems and their solution

Symptom	Solution
No output	Check DC power to MetPak II, cable and connections. Check communications settings of the MetPak II and host system match, including correct Com port. Check that the unit is in Continuous mode. Check that in-line communication devices are wired correctly. NOTE: It is usual for Anemometer TX + to be connected to converter device RX +. If appropriate use Safe Mode to attempt to obtain communication with the MetPak II.
Corrupted output	Check that the communication settings of the MetPak II and host system match. Try a slower baud rate. Check cable lengths and type of cable.
One way communication	Check that the wiring is in accordance with the manual.
Unexpected Temperature /Dewpoint readings	Check that the Temperature and Dewpoint units of measure (C, F, K) settings are correct on power up.
Unexpected Wind readings	Check that the Wind Sensor units of measure (m/s, knots, kph, ft/min, mph) settings are correct on power up.
Unexpected Temperature/Dewpoint and Humidity readings	Check that the HygroClip filter is clean.
Status code not 00 or A	See Table 12

Table 12 Status codes as output with the MetPak II data string

Code	Status	Condition
00	OK	No fault conditions detected in measurement period.
A	Acceptable data (NMEA Mode)	No fault conditions detected in measurement period.
01	Wind Sensor Axis 1 failed	U Axis blocked or faulty.
02	Wind Sensor Axis 2 failed	V Axis blocked or faulty.
04	Wind Sensor Axis 1 and 2 failed	U and V axis blocked or faulty
08	Wind Sensor NVM error	Non Volatile Memory checksum failed, data could be uncalibrated.
09	Wind Sensor ROM error	Read Only Memory checksum failed, data could be uncalibrated.
0B	Wind Sensor reading failed.	Wind Sensor faulty.
10	Hygroclip error	Hygroclip faulty.
20	Dewpoint error	Hub Pec faulty.
40	Humidity error	Hygroclip faulty.
XX	More than one fault	Fault condition that can be the sum of 0B, 10, 20 or 40. e.g 1B would mean that both the Wind Sensor (0B) and Hygroclip (10) were faulty.
V	Void Data, Wind Sensor reading failed. (NMEA Mode)	Wind Sensor faulty.

4.2 Servicing

In the event of failure, prior to returning to an authorised Gill distributor it is recommended that:

- All cables and connectors are checked for continuity, bad contact, corrosion etc.
- A bench test is carried out as described in the next section.

Contact your supplier if a fault persists.

4.3 Bench Tests

Carry out a bench test as follows:

1. Connect the MetPak II unit to the host PC and power supply, using a known working test cable.
2. Check that the unit is correctly configured by going into Set Up mode (see page 30).
3. Check for normal output data, and that the Status Code is OK – 00 or A.
4. If the status code is other than 00 or A, refer to Table 12 for a list of status (error) codes.
5. Use an office fan or similar to check that the unit is sensing wind, turning the unit to simulate changing wind direction and to check that both axes are functioning.
6. Check for output changes in temperature and relative humidity sensor (the fan will also cause small changes in these properties).



5. Maintenance

Wind Sensor (WindSonic)

If there is any build-up of deposits on the unit, it should be gently cleaned with a cloth, moistened with soft detergent. Solvents should not be used, and care should be taken to avoid scratching any surfaces. The unit must be allowed to defrost naturally after being exposed to snow or icy conditions, do NOT attempt to remove ice or snow with a tool.

There are no moving parts or user-serviceable parts requiring routine maintenance.

Opening the unit or breaking the security seal will void the warranty and the calibration.

UV Shield (RM Young Model 41003)

If there is any build-up of deposits on the unit, it should be gently cleaned with a cloth, moistened with soft detergent. Solvents should not be used, and care should be taken to avoid scratching any surfaces. The unit must be allowed to defrost naturally after being exposed to snow or icy conditions, do NOT attempt to remove ice or snow with a tool.

HygroClip for Temperature, Humidity and Dewpoint (Rotronic Model HC2-S3)

Periodically check the filter:

Corroded, discoloured or clogged dust filters should be replaced. Either replace the polycarbonate dust filter screw-on cap (Rotronic part NSP-PCW-PE) or replace the whole cartridge.

If you need to replace the dust filter cap, carefully unscrew it and withdraw carefully avoiding contact with the Temperature and Humidity circuit board. When re-fitting the filter cap, ensure the circuit board connections are not bent.

Consideration should be given to an annual calibration check of the HygroClip sensor by the manufacturer.

If you are replacing the whole cartridge, unscrew the metal ferrule and return the probe to Rotronic for calibration. Refer to the Rotronic Website for more details:

http://www.rotronic-humidity.com/content/dienstleistungen/reperatur/rma_anfrage.php



NOTE. If you return the sensor to a HygroClip supplier for exchange, please request that the return unit has the dewpoint feature enabled.

Barometer (on Hub PCB)

The Barometer device is maintenance-free, however, if required, clean the central Hub box screw cap Gortex filter with a small brush.

Returning the MetPak II

If the unit has to be returned, it should be carefully packed in the original packaging and returned to your authorised Gill distributor, with a full description of the fault condition. An RMA number should be obtained from Gill Instruments first if returning directly to Gill Instruments.



6. Technical Information

6.1 Specification

Wind Measurement	
Parameters	Polar Wind Speed & Direction or U and V Vectors
Units of Measurement	m/s, knots, mph, kph, ft/min

Wind Speed	
Range	0-60m/s (0-134mph)
Accuracy	± 2% @12m/s
Resolution	0.01m/s (0.02mph)
Threshold	0.01m/s (0.02mph)

Wind Direction	
Range	0-359 Degrees – No dead band
Accuracy	± 3° @12m/s
Resolution	1°

Air Temperature	
Type	Pt100 1/3 Class B
Range	-35°C to + 70°C
Accuracy	±0.1°C
Resolution	0.1°C (0.1°F)
Units of Measure	°C or °F

Relative Humidity	
Range	0-100%
Accuracy	±0.8% @23°C
Resolution	0.1%
Units of Measure	% RH

Dew Point	
Resolution	0.1°C (0.1°F)
Accuracy	±0.15°C (23°C ambient temp @20°C dew point)
Units of Measure	°C or °F

Barometric Pressure	
Range	600 to 1100hPa
Accuracy	±0.5hPa
Resolution	0.1hPa
Units of Measure	hPa, mbar, mmHg, InHg
Compensated for Temperature dependency –20°C to +70°C	

Outputs	
Digital Outputs	RS232, RS422, RS485 (2 wire point to point) or SDI-12
Baud Rates	1200 (SDI-12), 4800-57600 (ASCII RS232, RS422, RS485*)
Protocols	ASCII, SDI-12 V1.3 or NMEA 0183
Data Output	0.25, 0.5, 1 Hz or Polled Mode
MetPak II Status	Status codes provided within the data message string

Power Supply	
Input voltage (RS232, RS422, RS485)	4.5v to 30v dc
Current	16mA at 12v (default setting)
Input voltage (SDI-12)	9.6v to 16v dc (12v nominal)
Current	6.5mA

Environmental	
Protection Class	IP65
EMC	EN 61326
Operating Temperature	-35°C to +70°C
Storage Temperature	-40°C to +80°C
Humidity	0-100%

Mechanical	
External Construction	UV Stabilised white thermoplastic
Fittings	Gloss white painted aluminium mounting bracket (with moulded plastic V block and stainless steel U bolt), for attachment to a vertical pipe of diameter 25mm to 50mm.
Weight	1.1kg (including bracket)

6.2 MetPak II Hub PCB Connections

The following tables summarise the connections for:

- HygroClip (Factory Connections)
- WindSonic anemometer (Factory Connections)
- RS232/RS422/RS485 and SDI-12 communications (User Connections)

Connection details are also found on the hub box lid.

Table 13 HygroClip connections (6-way connector J1)

Connector J1	Wire Colour	Signal Name
1	Black (screen)	HygroClip Screen Wire
2	Blue	RXD from HygroClip UART
3	Red	TXD to HygroClip UART
4	Yellow	Analogue 0V (Not Used)
5	Grey	Supply/Signal 0V
6	Green	Supply +ve (+3.3V DC)

Table 14 WindSonic anemometer connections (8-way connector J4)

Connector J4	Wire Colour	Signal Name
1	-	No Connection
2	-	No Connection
3	Blue	RS232 TX+ Anemometer Output to Hub
4	White/Blue	RS232 RX+ Hub Output to Anemometer
5	Green	Signal 0v
6	White/Orange	Supply 0v
7	-	No Connection
8	Orange	Supply +ve (4.5v to 30V dc)

Table 15 PC communications (8-way connector, J5)

Connector J5	Signal Name
1	SDI-12 TX/RX
2	Signal 0V
3	RS232 TX- , (or RS422/485 TX-) HUB to user
4	RS232 RX- , (or RS422/485 RX-) User to HUB
5	RS422/485 RX+, User to HUB
6	RS422/RS485 TX+, HUB to User
7	Supply 0v
8	Supply +ve (4.5v to 30v dc)



NOTE. J2, a 12-way expansion board connector and J3, a 5-way connector are not used in the current version.